

Notebook

VOL. 2

**CBS
COLOR
RECEIVER
CIRCUITS**

Color
TELEVISION

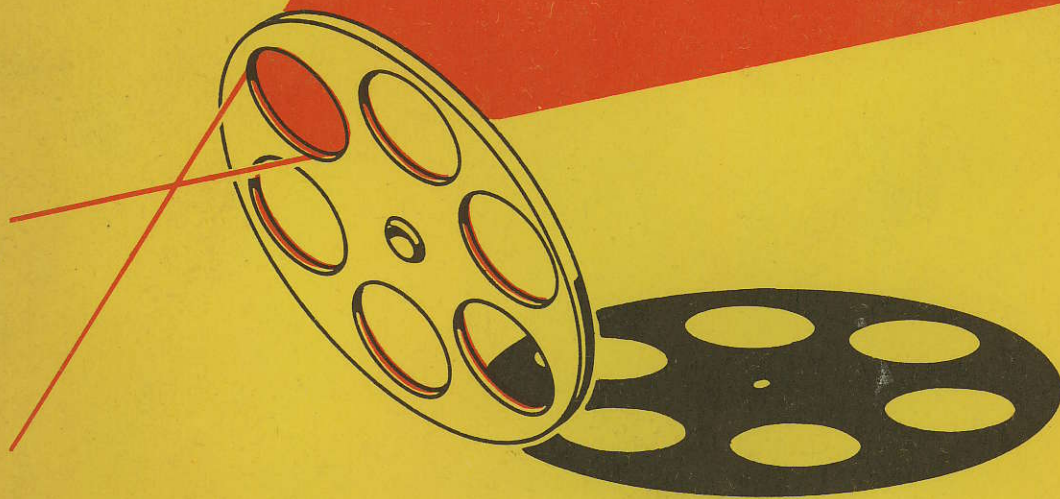

TELEVISION TECHNICIANS
LECTURE BUREAU

MERIT

Merit TV full-line* Components For Conversion or Replacement

MDF-30—new 70° "full focus" distributed winding "cosine" yoke—complete with network. For direct drive tubes up to 24".



HVO-8—air core "flyback" for direct drive systems.

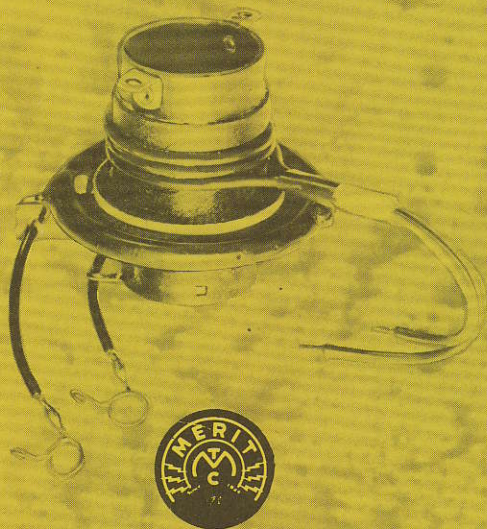

Merit... HQ for TV Service Aids

Keep ahead of TV conversion and component replacement service problems—write MERIT... HQ for TV Service Aids... get your free copy of the industry's most complete TV Replacement Guide—Form #404—plus other invaluable service data!

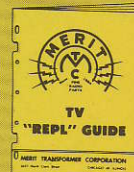

These 3 Merit extras help you:

Exclusive: Tapemarked © with specs. and hook-up data.

Full technical data packed with every item. Listed in Sams Photofacts.

*Merit is meeting the TV replacement component and conversion demand with a line as complete as our advance information warrants!

COLOR TELEVISION

Volume 2
(Notebook #3-A)

SOME FUNDAMENTALS OF COLOR TELEVISION SYSTEMS

By W. B. Whalley
Adjunct Professor
Polytechnic Institute of Brooklyn

RECEIVER CIRCUITRY FOR CBS COLOR TELEVISION SYSTEM

By A. A. Goldberg
Engineering Research & Development Laboratories
Columbia Broadcasting System

THE CBS-COLUMBIA COLOR COMPANION RECEIVER

By Edward M. Noll
Technical Consultant
Television Technicians Lecture Bureau

THE TELE-TONE COLOR COMPANION RECEIVER

By Elias Cohen
Tele-Tone Radio Corporation

and

Allan Easton
Communications Engineering Division
Radio Receptor Company, Inc.

All Art Prepared by

THE BARNARD STUDIOS
Indianapolis, Indiana

Copyrighted September 1951 by the
PAUL H. WENDEL PUBLISHING COMPANY, INC.
P. O. Box 1321
Indianapolis, Indiana

All rights reserved

For Greatest
TV Picture Quality

AMPHENOL → **INLINE** *

*Reissue Patent No. 23,273

TV ANTENNAS

OUTSTANDING MECHANICAL SPECIFICATIONS

Part	Material	Yield Strength	Size	
		psi	o.d.	Wall
Mast (galv.)	3/4" Thinwall Steel Conduit	32,000	0.922"	.049"
Large Folded Dipole	3S 1/2 H Al.	19,000	.500"	.049"
Small Folded Dipole	3S 1/2 H Al.	19,000	.375"	.049"
Reflector	3S 1/2 H Al.	19,000	.500"	.049"
Crossarm	3S H Al.	26,000	.875"	.065"
Center Support & T Casting	Al. Alloy 45,000 psi tensile strength			

EXCELLENT RADIATION PATTERNS

These are the radiation patterns of the AMPHENOL Inline antenna at 58 mc., 66 mc., and 88 mc., in the low band, and 174 mc., 194 mc., and 215 mc. in the high band. Notice the uniformity of these lobes at all frequencies. The lack of lobes off the sides and negligible ones off the back maintains high front-to-back and front-to-side ratios necessary for the rejection of various interferences. The

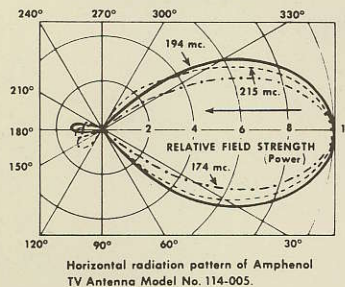
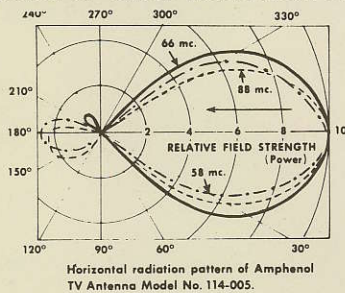

presence of a single forward lobe is usually a very desirable feature, especially when it is wide enough to provide adequate interception area for some differences in transmitter location, changes in the wave front's direction of travel, or physical movement of the antenna in high winds. Furthermore, it is not too critical of orientation. It is necessary only to aim it and forget it.

HIGHER GAIN

These gain curves of the AMPHENOL Inline antenna represent the intercepted voltage of the AMPHENOL Inline Antenna as plotted against the intercepted voltage of a reference folded dipole cut to the frequency being compared. There is no channel in either the low band or high band where there is more than a three decibel change within the channel that can cause picture modulation or "fuzziness." The gain of the AMPHENOL Inline antenna is quite flat over all channels.

You will find more gain designed into the high band because of greater need for it, due to higher losses at these frequencies. Also, notice the drop-off on channel six. This is at the edge of the FM band and is subject to FM interference, so the Inline's gain is purposely held down at that frequency.

The excellent broadband characteristics, impedance match, single forward lobe radiation patterns on all channels, maximum gain, lightning protection, and superior mechanical features of the AMPHENOL Inline Antenna make it the antenna for the greatest TV picture quality!

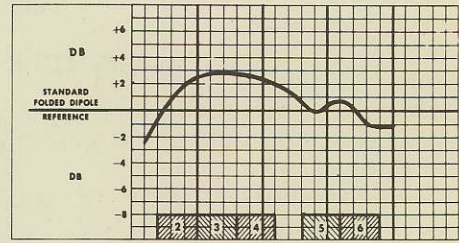

Gain of Amphenol Model No. 114-005 Antenna over a reference folded dipole, 54 to 88 mc.

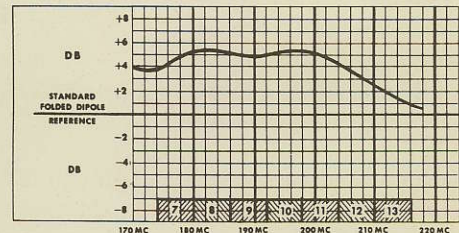

Gain of Amphenol Model No. 114-005 Antenna over a reference folded dipole, 174 to 216 mc.

YOURS FOR THE ASKING

Send for "The Antenna Story" — a sincere discussion of TV antennas based on actual field tests.



AMPHENOL AMERICAN PHENOLIC CORPORATION

1830 SOUTH 54th AVENUE • CHICAGO 50, ILLINOIS

TABLE OF CONTENTS
 Notebook #3-A
 COLOR TELEVISION - Volume 2

	Page
SOME FUNDAMENTALS OF COLOR TELEVISION SYSTEMS.	5
Fundamental Physics	5
Basic Methods	5
Frame Sequential System	5
Line Sequential System	6
Multiple Systems	7
"Simultaneous All-Electronic" - RCA.	7
Dot Color System P.A.M. - RCA.	7
Physical Problems of Non-Frame Sequential Systems	7
Physical Simplicity of Frame Sequential System	8
Compatibility	8
Versatility	8
Some Practical Considerations.	8
Economics	9
Installation Costs.	9
Maintenance	10
 RECEIVER CIRCUITRY FOR CBS COLOR TELEVISION SYSTEM.	 11
Standards	11
Signal Considerations	12
Horizontal Scanning	13
Vertical Scanning.	18
Hum	19
Possible Picture Defects and Their Causes	22
Horizontal Jitter	22
Vertical Jitter and Poor Interlace.	22
Flicker and Flutter	22
Misregistration and Color Fringing.	23
Color Shading	23
 CBS-COLUMBIA COLOR COMPANION RECEIVER	
Circuit Diagram	24
Description of Circuitry	25
 TELE-TONE COLOR COMPANION RECEIVER	
General Requirements	29
Types of Systems	29
Block Diagram of Tele-Tone Color Companion Unit.	30
Description of Companion Unit.	31
Connection to black-and-white Receiver.	31
Breakdown of Circuitry	
The Video Amplifier System	31
Circuit Diagram - Video Amplifier.	32
Sync Separator	33
Vertical Deflection.	33
Sync Separator & Vertical Deflection Circuit Diagram	34
Horizontal Deflection & High Voltages	35
Power Supplies	35
Motor Speed Control Circuits.	35
Schematic - Horizontal Output Circuit & Power Supply	36
Interconnection with Monochrome Receiver	37
Motor Speed Control.	38
Probe to Connect to black-and-white Receiver	39

HERE'S THE BEST FOR EVERY TEST

Sylvania Radio and TV Testing Equipment

Television Oscilloscope

An exceptionally High-Gain, Wide-Band Oscilloscope Designed for Television. Accurately displays any TV pulse or wave-shape on a large, eye-saving 7" screen. Sensitivity: 0.01 v./in. Vert. response useful to 4.0 mc. Hard-tube sweeps to 50 kc; phasing control; pos. or neg. sync. control; many other outstanding features. Recommended for servicemen; laboratories; advanced schools and industry. Price \$249.50.

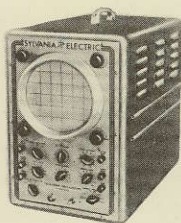

Type 400

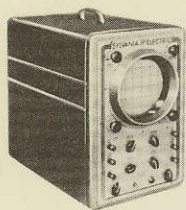

Type 132 Z

General Purpose Oscilloscope

A Versatile 7" 'Scope with Many Features Found in Type 400 above, priced as low as oscilloscopes with smaller screens. Sensitivity: 0.1 v./in.; freq. response: exceeds 7 cps. to 70 kc. Widely used by servicemen, schools and industry for AM-FM-TV testing. Price: \$149.50.

Tube Tester Type 220 Made by a Tube Manufacturer for Tube Users, these instruments test for ALL usual faults—not just one particular characteristic. New and exclusive ohmmeter-type shorts/leakage test indicates "GOOD" or "REPLACE," directly on the illuminated meter. Gas and special heater-cathode leakage tests made in single operation.



Single composite dynamic test for emission, trans-conductance and relative tube life. Panel-mounted roller-chart; convenient switches; provisions for future tubes. Portable Type 220 has durable metal case and handle; removable cover. Size: 6" x 11 $\frac{1}{4}$ " x 17". Price: \$114.50.

Tube Tester Type 219 The counter Type 219 is electrically equivalent to the portable type. Attractively housed in a streamlined wood and metal cabinet. Adaptable to any surroundings. Occupies small counter space. Size: 5 $\frac{3}{4}$ " x 13" x 18 $\frac{3}{4}$ ". Price: \$114.50.

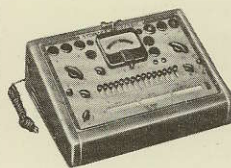

TV Sweep Signal Generator

An ALL ELECTRONIC Sweep Generator for TV and FM. Fundamental center frequencies: 2-25, 20-64, 60-120, and 140-230 mc. Two adjustable sweep widths: 0-600 kc./15 mc.; excellent sweep linearity; output 0.1 v. Edge-lighted dial; simplified controls; small size: 11 $\frac{1}{2}$ " x 8 $\frac{1}{2}$ " x 7". May be used with any 'scope and marker, including those shown above and below. Price: \$139.50.



Type 500

Polymer-TV Vacuum-Tube Voltmeter

A Sensitive DC, AC and RF Vacuum-Tube Voltmeter, Ohmmeter and DC Current Meter. The basic instrument for every TV, FM and AM shop. Ranges: rf to 300 volts (only 3 μ mf shunt capacity); ac and dc to 1000 volts (10 or 30 kv dc using h.v. probes); dc current from 50 micro-amperes to 10 amperes; and resistance from 0.5 ohms to 1000 megohms. Frequency range to 300 megacycles. High input impedance on all voltage ranges. Size identical to TV generator at left. Price: \$99.50.

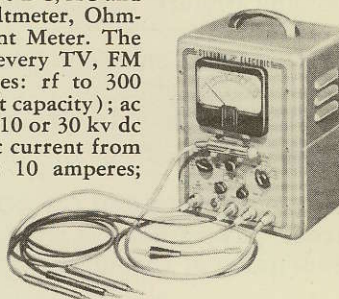

Type 221 Z

FM-AM Signal Generator

Useful as a TV Marker. A versatile AM-FM generator, doubly useful for peaking alignment of TV and as a TV marker. Calibrated to 0.05%. Fundamentals 80 kc to 120 mc; harmonics to 240 mc. Modulation: 0-100% AM; 0-30/150/700 kc FM. 1.0 volt max. output. Low leakage. Built-in circuit for external crystal. Price: \$139.50.

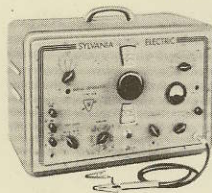

Type 228

Cathode Ray Tube Testing Adapter. Use with any Sylvania Tube Tester to check 85% of your picture tube troubles, without removing tube from receiver. Checks electro-magnetic types for emission, shorts, leakage, and open filaments. Price: \$9.50. Type 228.

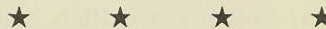

For full information about Sylvania's complete line of quality testing equipment, write today to: Sylvania Electric Products Inc., Dept. R-2807, Emporium, Penna.

SYLVANIA ELECTRIC

RADIO TUBES; TELEVISION PICTURE TUBES; ELECTRONIC PRODUCTS; ELECTRONIC TEST EQUIPMENT; FLUORESCENT TUBES, FIXTURES, SIGN TUBING, WIRING DEVICES; LIGHT BULBS; PHOTOLAMPS; TELEVISION SETS

SOME FUNDAMENTALS OF COLOR TELEVISION SYSTEMS

BY

W.B. Whalley
Adjunct Professor
Polytechnic Institute of Brooklyn

I. FUNDAMENTAL PHYSICS

What must be added to a standard type of monochrome television signal to provide color reproduction?

1. Hue only, since (a) resolution, (b) brightness, and (c) synchronizing information are already present in the monochrome signal. *(See editor's note)

II. BASIC METHODS

What are the basic methods of accomplishing I?

1. Color information associated with the synchronizing signal.
 - a. Frame Sequential (example; Baird - CBS) Mechanical or "all electronic"
 - b. Line Sequential (example; C.T.I.) - (Must be "electronic" only).
2. Multiple Complete Systems; - A television system for each Primary Color. Example; RCA "Simultaneous-All Electronic" of 1946-48.

3. "Sub-carrier" Systems which include:

- a. Synthetically - the dot color system (RCA of 1949-50) Pulse Amplitude Modulation (P.A.M.) - must be "electronic" only.
- b. Band-sharing methods, eg. G.E. - Must be "Electronic" only.

BRIEF DESCRIPTIONS OF 1, 2, and 3.

1a. - The frame sequential system was first demonstrated in approximately 1934 by Baird, and makes use of the very simple and practical technique of viewing the scene through color filters which are placed in time sequence between the camera and the scene so that the television camera first looks at the scene through one optical light filter (say green) such as one of the Wratten gelatin transparencies, then at a later time corresponding to one vertical scan period, views the scene through, say, a red filter, finally a blue filter.

Each of these transparency filters behaves with light frequencies as though it were a bandpass filter in the terminology of radio. It is inter-

EDITOR'S NOTE

One of the greatest difficulties with the dot sequential system is the synchronization of the receiver color switching function.

In order to retain compatibility, R.C.A. and others, notably the new NTSC of the RTMA, employs a sineusoidal burst at the beginning of each line. This one burst is then expected to synchronize the receiver's sub-carrier oscillator accurately enough so that nearly 400 free running switching operations occur across the line. If the free running color switch timing varies by just a small amount, color contamination becomes severe.

The synchronizing burst is intentionally made small in amplitude, about 10%, in order to retain compatibility. Any CW interference within the channel that sets up a beat at or near the sub-carrier frequency has a very detrimental effect on an already touchy synchronization problem. The CW interference mentioned is usually local oscillator radiation, a very common condition.

From the above, one can assume that the synchronization problem of the dot-sequential system is an extremely difficult one.

esting to note, by the way, that each of these bandpass filters is a remarkably stable and low cost device as compared with typical electronic circuit bandpass filters.

At the receiver, the observer views the normal type of picture tube through similar color filters which come into position, in front of the picture tube, in synchronism with those at the transmitting end.

It must be emphasized that with suitable (yet to be designed!) cameras, and suitable simple tri-color picture tubes*, this system-frame sequential-lends itself better to "all electronic" operation than any of the other systems to which reference will be made. Hence, the frame sequential system can be both mechanical and "all electronic" and can, therefore, provide a versatility which other higher speed or shared color switching systems do not.

*Some tri-color reproducing tubes can be simpler and lower in cost for the Frame Sequential System than any other system due to low switching rate.

1b. - Line Sequential - If we consider line sequential systems, -where the color is changed with each line of the scanning, -we reach switching speeds where mechanical methods become inadvisable.

Hence, the need for performing this (if it is a desirable system?) by electronic methods.

In its basic form, this involves viewing the scene through separate sectional color filters, or with camera tubes which are separately color sensitive by suitable means, and then at the receiver, viewing the incoming signals on either a single "tri-color" tube or a bulky three-picture tube assembly unit; since it is not practicable to switch color filters at a rate of 15,750 per second (fH monochrome) by mechanical means.

The first attempts to "sell" the line sequential system (C.T.I.) were arranged in, possibly, the most difficult way. Three lens were placed side by side horizontally, in front of the mosaic of a standard television camera tube and attempts were made to place the scene on the mosaic as three small scenes which had as precisely as possible the same width, same height, same optical linearity in both the horizontal and vertical directions; also, -spaced apart physically on the mosaic such as to mesh in with the blanking period of a standard 15,750 monochrome synchronizing signal.

To be successful, the optical and mechanical registration of each of these three images on the mosaic, would have to correspond in width to an accuracy of better than 1/9 of 1% and in height to better than 1/15 of 1% in order to maintain reasonable resolution of the pictures. Furthermore, the linearity of each of the images would have to have a corresponding accuracy.

Between each lens and the mosaic there was a section of color filter transparency. Then a single scanning beam, as is present in the standard pick-up tube, scanned across the mosaic at 1/3 of the normal horizontal monochrome scanning speed so that three of these horizontal line picture sections would be transmitted in the time of one scan.

Another larger problem occurred immediately (and should have been thought of before). Since three pictures of standard shape had to be placed side by side with spacings between them corresponding to the lost blanking times, less than 1/10 of the useful area of the mosaic was used for each image. As is well known, pick-up tubes are already limited in their available resolution; -cutting down the area per image to approximately 1/10 of normal, means that the detail resolved by the scanning beam would be much inferior to that of a standard monochrome or frame sequential color full-area image.

In addition to the enormous problem of the optical and mechanical registration plus size similarity of the three images, there was also the fantastic problem of attempting to maintain a precisely linear horizontal scanning during the whole time of sweeping across the three images, since a deviation in electrical scanning linearity of 1/27 of 1% would correspond to a deviation in placement of the element information in one image with respect to another of the images of the order of 1/9 of 1% (as mentioned above as being a reasonable maximum limit for the optical accuracy).

Another most serious fundamental problem of "line sequential" (forgetting about the reproducing device) is that of "line crawl" and "line jitter". Whatever sequence of color line switching is taken, whether it be 1-2-3, 1-3-2, 3-2-1, the eye sees a very definite crawling effect going either up or down. This effect is so serious, that an observer would have to view the picture from a much greater distance than would be comfortable for monochrome viewing with the same number of scanning lines; therefore, effectively making the available hypothetical information of no consequence, for he is automatically cutting down the amount of useful information by viewing it at a distance where the eye can no longer resolve the element detail in the picture.

II. 2. Multiple Systems (one for each color); RCA.

"Simultaneous all electronic" system. Here, there was to be a complete camera, pre-amplifier line-amplifier, transmitter with receiver tuner, i.f., video, and reproducing device for each primary color, with the hope someday of having, (a) a single camera to supply correctly-registered and signal-amplitude controlled three color video signals and (b) a single reproducing device to give one color picture from three video signals.

This proposed system had all the registration and other problems of those which follow (except for the effect of % modulation in the Dot Color Sequential System) to say nothing of the complexity of apparatus and the major problem that propagation conditions could, due to there being a separate carrier frequency for each primary color, cause errors in hue and also "ghost" in separate discrete primary colors.

3. The Dot Color System P.A.M. (RCA)

During 1949, RCA engineers endeavored, by what is undoubtedly a clever scheme, to take the signals from three complete cameras assembled in a unit, (carried over from the early "simultaneous system" of RCA) and, in time sequence, place the signals through a single transmitting system.

This approach was by electronically sampling the output signals from the three camera tube pre-amplifiers at a rate of 3.58 Mc/sec and an approximate duty cycle of 6%; that is, one pick-up tube amplifier would be connected to the main system for a period of approximately $\frac{1}{3.58 \times 10^6}$

seconds; disconnected for $\frac{4}{15}$ of $\frac{1}{3.58 \times 10^6}$

seconds, then the next pick-up would be connected similarly, and followed by the third pick-up tube. The sequence would be repeated every $\frac{1}{3.58 \times 10^6}$ seconds.

The output pulse signals from this electronic sampling device were, therefore, in the form of P.A.M. modulation, then passed through the standard studio line amplifiers to the 4 Mc wide television transmitter modulator. Due to the P.A.M. signals, there was produced a sub-carrier at 3.58 Mc which appeared on both monochrome and experimental color (never correctly registered) receivers as a dot pattern which dot

pattern had an equivalent resolution almost exactly twice as coarse as the line structure of the picture (calculation will show that 3.58 Mc. in a 525 line system corresponds to 285 line resolution; to compare with the 490 visible writing lines of the picture). Aside from the complexity of synchronization of the electronic switching at the receiver to keep precisely in step with that at the studio, there is the major fundamental problem only realized later:--

Another Fundamental Physical Problem in this Dot Color System (P.A.M.) (RCA)

There is an additional major physical problem above those of all the other systems, that is, that with our standard vestigial side-band system, the hue of the received signal changes with the brightness, irrespective of the pick-up or reproducing devices. One of the reasons is that the slope of the leading and falling edges of a pulse change with the percentage of modulation; as the brightness decreases and correspondingly the percentage modulation increases, the slope becomes more gradual (corresponding to an effective narrower bandwidth), therefore, changing the percentages of the pulses for the relative color components and thereby changing the hue. (Reference: RCA Review, April 1940, page 432, by R.D. Kell and G. L. Fredendall.)

3b. The band-sharing sub-carrier methods, G.E. and others, could avoid the dot and % modulation hue problems of the previous II-3-a system but have all of the other pick-up device and reproducing device problems which brings us to:

III. PHYSICAL PROBLEMS OF NON-FRAME-SEQUENTIAL SYSTEMS

What do II-1, 2, and 3 involve in fundamental physical problems?

With the exception of II, 1a (frame sequential) all of these methods involve multiple area pick-up information and multiple area reproduction together with separate systems or sections of systems and associated components at both transmitters and receivers for each primary color signal. These involve 4 major physical problems:--

1. Registration, optical and/or electronic, at both pick-up and reproducing.
2. Level Control, variations in gain of one color channel with respect to another color.
3. Area Sensitivity Variations, such as

the differences between one pick-up tube mosaic and another.

4. Grain Size, reproducing devices having insufficient number of elements (example, RCA 200,000 hole "tri-color" tube) giving "Moire" effect.

NOTE:

There is a special boundary case with these systems - a unique case - that of a flying spot scanner using color transparencies where problems 1, and 3 are eliminated, (as in the experiments at Hazeltine) at the transmitting end. But, for "live pick-up", physical and electrical registration and variations in area sensitivity of the mosaics of the pick-up cameras are a very real problem.

IV. FUNDAMENTAL PHYSICAL SIMPLICITY OF FRAME SEQUENTIAL SYSTEM.

The frame sequential system whether it is operated by "all electronic" or mechanical filter switching, is the only one with all of its components present for each color at all times. Hence, all color signals are handled in the same way, having the same system gain and maintaining the same gain for each color component. Also, there is no inherent registration problem at either end of the system. There is no problem of variation in area sensitivity of one mosaic with respect to another because there need only be one mosaic which, therefore, has the same area variation for each one of the color components introduced. (No two image orthicon tubes are alike!)

V. COMPATIBILITY

Since the CBS System does not have the same FH or vertical as in 525 line monochrome transmission, "Compatibility" has been a complaint.

1. For this to be of major importance, it must be assumed, from a basic physics standpoint, that the present monochrome signal has the ideal number of writing lines. Since it was contended by the eminent television engineers and scientists in the period 1938 to 1941 that from 410 to 430 writing lines would be the ideal choice (Zworykin, Kell, etc.), it is not reasonable from a fundamental physics standpoint, to make a major issue of keeping 525 writing lines in a raster.

2. Instead, emphasis should be placed on having a color television system for practi-

cal realization of optimum within bandwidth color at the receiver and not that the color scene may be received in "monochrome".

VI. VERSATILITY:

Both mechanical and electronic versus,-

Electronic only.

There are so many continuing problems in connection with the variations in light output with beam current for various single color phosphors eg. a phosphor giving efficient red light output has a different curve of light output vs. beam current than, say, a green phosphor, that a system which cannot be other than "all electronic" has fairly rigid restrictions (entirely aside from those of complexity and III above.)

VII. SOME PRACTICAL CONSIDERATIONS:

A color television system, to be satisfactory for use in the home, must be as simple and rugged as possible.

A large enough percentage of users of monochrome television receivers have had trouble due to poor initial and service adjustments of the receiver, eg., focus, brightness, linearity, centering.

Let us consider some of the operating and adjustment problems of one of the "all electronic subcarrier and line sequential" systems. First of all, at the receiver let us imagine a reasonably satisfactory tri-color picture tube has reached the stage of mass production (this still appears to be some time in the future).

The following are some of the problems which will continue from day to day;--

1. The maintenance of correct phosphor timing, from one primary color to another or the maintenance of constant gain in each of the three video amplifiers.
2. The basic problem of maintenance of correct phase response in the receiver, (eg. the i-f amplifier) over a large range of signal amplitudes.

With a three-gun reproducing tube, there are further problems:--

3. The "almost impossible" problem, even on a laboratory basis, of maintaining all three electron beams in accurate registration over the whole face of the

picture tube. Such effects as changes in the earth's magnetic field or movement of the receiver with reference to the earth's magnetic field can cause serious loss of registration unless adequately shielded.

4. With the type of tube proposed by RCA at the latter part of 1949, we have the grave problem, in addition, of "grain size". ("Moire" effect)

As is known in photographic work, there should be at least two or three grains for each small item of information in the picture;--what, therefore, can be the quality of a picture when the number of grains equals 200,000 and the number of elements per frame in a full 4 Mc bandwidth is approximately 250,000?

There will automatically be a response to this statement - "that the number of holes can be increased". Unfortunately, aside from the increasing difficulty (and it is already extremely difficult to maintain alignment between the holes and the phosphor dots) there is the problem of mechanical and electrical strength of the aperture plate as the number of holes is increased.

The aperture plate with only the 200,000 holes can be seriously warped as the magnitude of the electron beam current of the gun or guns passes a value which would have no deleterious effect upon normal monochrome picture tube.

If, therefore, we had a picture tube with 600,000 holes and a corresponding number of clusters of color dots, then the metal in the plate would of necessity be so thin that there would be a severe restriction on:

- (a) Maximum beam current with full raster.
- (b) Maximum beam current with small raster area (as can so easily occur if horizontal or vertical deflection should momentarily fail).

VIII. ECONOMICS

It must be emphasized that in order to get color at the receiver, all systems involve new equipment in the home. (There seems no sense in putting color on the air to be received only in monochrome).

Hence, we come to the relative costs:

A. FIRST COST: SUBCARRIER METHODS:

Even with intensive effort over a long period, all of the sub-carrier methods will give a much more expensive receiver than the frame sequential system.

- (1) The dot color system involves a reproducing device which can switch at a high rate of speed-3.58 Mc per second-involving electronic circuits of a high degree of complexity and timing accuracy. The band sharing methods involve accurate bandpass and low pass filters with additional control circuits for either the three gun tube or the triple control of the target screen tube (depending upon which basic type of picture tube might be attempted.)
- (2) The problem of maintaining the same gain for each of the colors is quite serious.
- (3) The setting up for attempted registration of the three electron beams over the face of the picture tube - for a type of tube using 3 guns, - is a grave one.

The Frame Sequential System

As mentioned before, this provides a choice of simple mechanical reproduction added to an otherwise standard receiver design or - electronic control of color with a suitable tri-color tube which can be a very simple tube since the "switching" speeds are very low. Such switching circuits need negligible tube dissipation and "B" supply power (1 of 6SN7 would probably be adequate for switching the colors in the type of picture tube in which color control occurs at the screen). For a mechanical reproducing receiver, and there should be no basic objection to using mechanical engineering when it can provide an excellent solution more efficiently and at lower cost than electronic solutions (do not let us forget the fundamental need of mechanical devices in all sound recording, eg. phonograph records) then for synchronization of the color disc or drum, it is necessary to have only a two tube unit taking negligible B supply power. Hence, the additional cost to that of the normal monochrome receiver is very small.

B. INSTALLATION COST

Installation of receivers of the sub-carrier type would be an involved and expensive procedure.

One example, the need of keeping the receiver in a permanent position so that the vector of the earth's field would arrive at the same angle continuously with respect to the field in the focussing and deflecting systems unless adequately shielded. (This refers particularly to a three gun type of tri-color tube).

It is hardly necessary to point out how difficult it would be to estimate the expense of setting up such a receiver.

Frame sequential color receivers, however, can be set up just as easily as a monochrome receiver; in fact, there is no difference, in the work of setting up. Also, the user need only push a button to change from monochrome to color.

C. MAINTENANCE COST

Again, with reference to the broad group of sub-carrier type of systems it is easy to see the difficulties of maintaining the deflection amplitudes, linearities, registration of electron beams, the relative voltage levels for the different colors, the correct frequency and phase response of the circuits (particularly the bandpass and low pass electrical filters when an amplifier tube has to be changed) to realize the high cost of such maintenance.

However, maintenance of the frame sequential system equipment with mechanical or "all electronic" is very simple; with the mechanical type of reproducing unit maintenance cost would be almost precisely the same as for standard monochrome receivers.

RECEIVER CIRCUITRY FOR CBS COLOR TV SYSTEM

By

A. A. Goldberg

INTRODUCTION

Despite the fact that CBS has publicly demonstrated all-electronic receivers, at the present state of the art, the disk type color receiver is the simplest and provides the highest order of color fidelity. (See page 8, Color Television Notebook, Volume One.)

From here on, the term "color receiver" shall imply a field sequential receiver using rotating color filters.

A color receiver is basically a monochrome receiver with a more elaborate form of "Z" axis modulation. Instead of the modulation being restricted to a two point system of black and white and the intermediate greys, it now has the freedom of a three point triangular system and

all the colors and shades bounded by the points. Like monochrome television, it employs a sequential system for conveying information, the moving spot of light not only sketches out the geometric detail, but also is made to change color at a field rate. This color-monochrome comparison is mentioned to indicate that a good color receiver is theoretically nothing more than a good monochrome receiver with a few added functions. It is for the purpose of discussing these added functions that this article is presented.

STANDARDS

We are all acquainted with the monochrome standards. Percentage wise, color standards are similar, except for the addition of the color pulse and the change in the vertical blanking time.

	FIELD RATE	LINE RATE	VERT. BLANK	TIME VERT. us.	TIME V. RETRACE us.	TIME HOR. us.	TIME H. RETRACE us.
MONO	60	15750	5%	16700	454	63.5	8.89
COLOR	144	29160	7%	6950	141.1	34.4	4.83

Figure 1. Comparison - Monochrome and Color TV Standards

Figure 1 shows the pertinent differences between the two standards. As we shall see later, the only figure of primary significance is the horizontal retrace time.

Color television brings with it a new terminology. A "color field" is half the scan lines (odd or even) reproduced in one color; the color field rate for CBS color television is 144 per

second. A "color frame" is made up of three fields reproducing the three colors and is accomplished in 1/48 second. A "color picture" is completed when all lines have been scanned in all colors and includes six fields in the time of 1/24 second. The "color sequence" is red, blue and green, and the "color pulse" always precedes the red field.

1/24 SEC COLOR PICTURE	}	(1	RED	ODD)	} 1/144 SEC COLOR FIELD
		(2	BLUE	EVEN)	
		(3	GREEN	ODD	} 1/48 SEC COLOR FRAME
		(4	RED	EVEN)	
		(5	BLUE	ODD)	
		(6	GREEN	EVEN)	

Figure 2. Sequence of Color Scan - CBS Field Sequential System

SIGNAL CONSIDERATIONS

The increased line rate and the increased field rate compared with standard monochrome television results in a corresponding loss of geometric definition. It is imperative, therefore, to design the receiver for the maximum band width acceptance to avoid fidelity loss. Conventional tuners and I.F. amplifiers are successfully employed, if they are adjusted to provide smooth response.

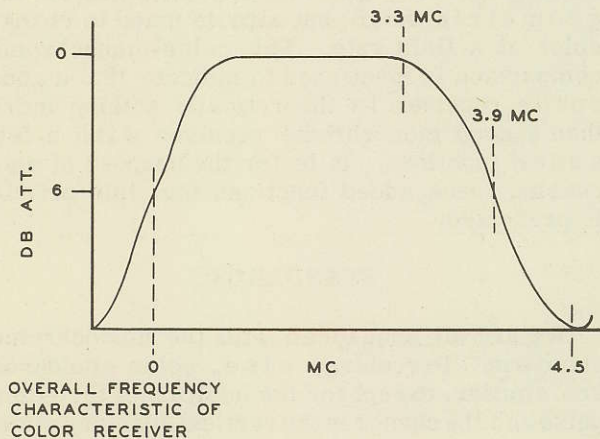

Figure 3. Overall Frequency Characteristic of Color Receiver

The response shown in figure 3 is recommended for good results. As in monochrome, ringing in a color picture is objectionable. It is worthwhile remembering that in color, ringing at a given frequency shows up as transients spaced nearly twice as far apart as in standard monochrome television.

To a considerable extent, the quality of a color picture depends upon the characteristics of the video amplifier.

Video compression in monochrome television, while objectionable, is not of prime importance. A normal viewer is more tolerant of grey scale compression than of color distortion. One theory for this is that the eye perceives a much smaller color irregularity than a brightness irregularity.

When a picture of the correct gamma is being transmitted, a receiver video amplifier with a linear dynamic range provides the highest order of color fidelity. When a kinescope with a different grid drive, brightness characteristic than is found in a 10FP4 is employed, the video amplifier should be changed to correct the difference.

The usual video amplifier is linear up to a certain point. If only the high amplitude field tips enter this curved region, the result is a definite white compression because the amplitude difference between fields disappears. Color, however, remains faithful on all but the picture highlights. Most of this compression is localized in the video output stage.

At this point, an examination of the kinescope drive requirements is in order. If a filter disc with a light transmission of 10% is employed, a kinescope brightness of 150 foot lamberts is required for a final color picture brightness of 15 foot lamberts. A 10FP4 kinescope operating at 13 KV, requires a grid drive of approximately 50 volts. Assuming a 75-25 video-sync ratio with no sync compression, a total of 67 volts must be handled. Allowing a suitable safety factor raises the value to 75 volts.

The Eg bias point determines the position of the average axis of the signal on the characteristic curve. If a one-stage video amplifier is directly coupled to the second detector, the Eg varies with the signal strength. This results in a wider video swing requirement. Although a triode can handle the peak current of 25 milliamperes, high current pentodes, such as the 6BF5 or 6Y6G, are preferable.

One method of reducing white compression with small video output tubes is to use cathode drive on the kinescope. Here, the sync instead of the peak whites are placed in the non-linear portions of the characteristic curve. Black compression, however, also produces objectionable distortion and should also be avoided.

Just some words of caution when using cathode drive on the kinescope; less kinescope gain is realized and dc restoration becomes more complicated. To amplify this last point, consider figure 4.

Here it is clear that both the restorer current and the kinescope beam current flow through the same resistor but in opposite directions. D.C. restoration is thereby impaired whenever picture brightness is turned up. One practical method for accomplishing cathode drive is to direct couple to the kinescope cathode and restore the dc in the video amplifier grid circuit.

The response-frequency characteristic of the video portion of the receiver should be as flat as practical, with a smooth roll-off at the high frequency. When one or more of the fields is of different amplitude from the rest, the video signal contains a 48 cycle component. Excessive 48 cycle tilt may cause uneven field amplification with resulting color distortion. It is good

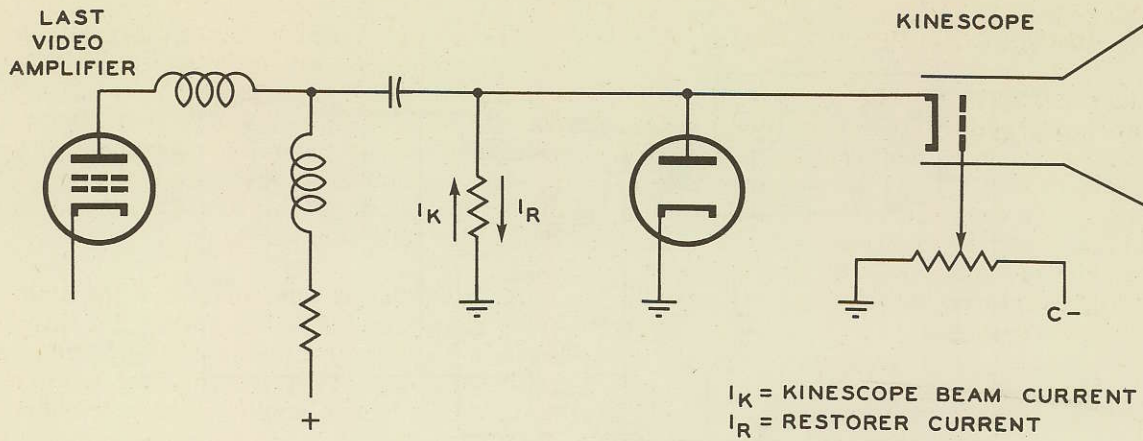

Figure 4. Cathode Drive on Kinescope

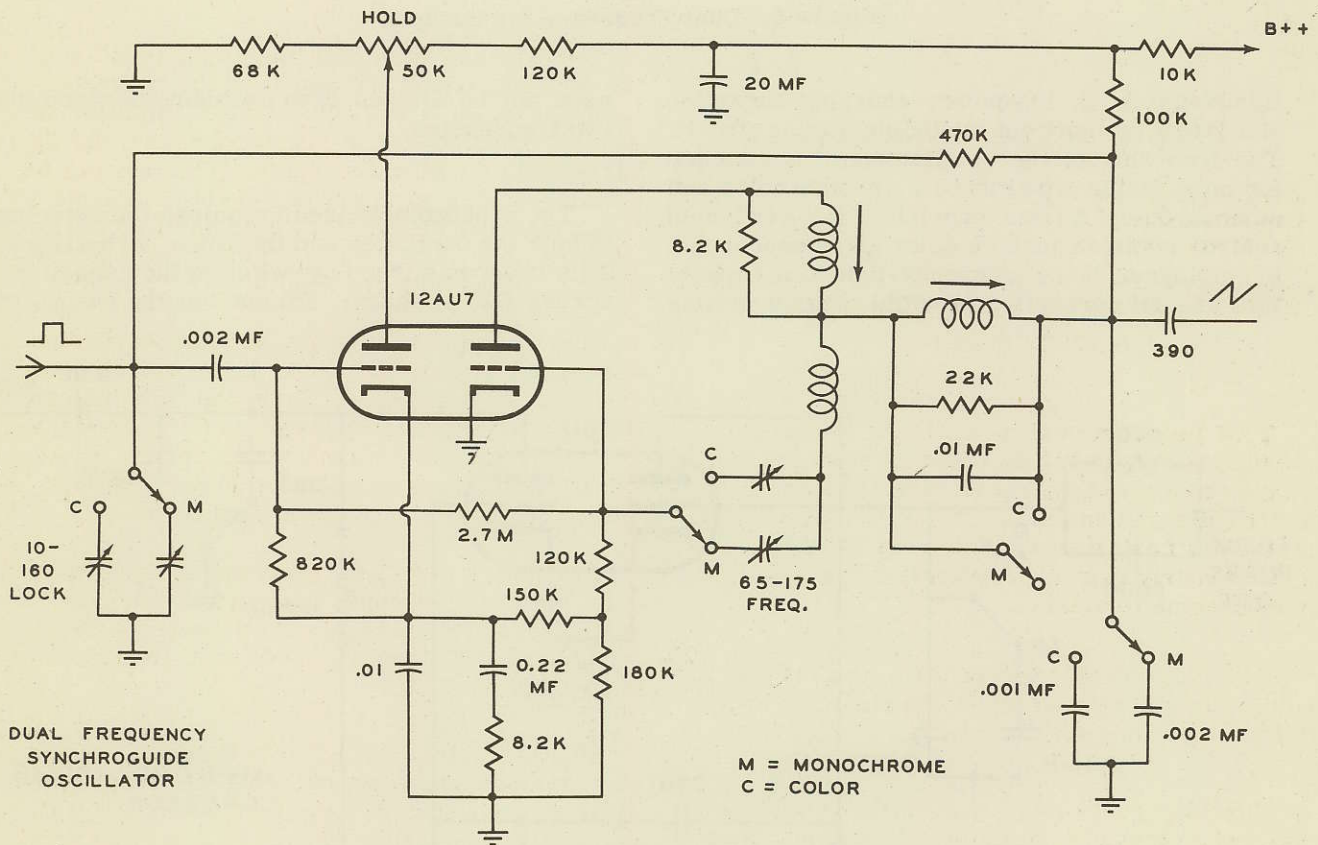

Figure 5. Dual Frequency Sychroguide Oscillator

practice, therefore, to compensate the low frequency response down to 30 cycles with a maximum of 15% tilt up to the grid of the video output stage.

HORIZONTAL SCANNING

Present-day horizontal oscillator circuits that are used for monochrome television are

easily modified for color. All that need be done is to change the frequency of oscillation from 15750 cycles to 29160 cycles per second. A few examples of dual frequency horizontal oscillators are shown here.

A conventional four pole, two position wafer switch is utilized for dual frequency circuits. A total of four poles are used to switch the

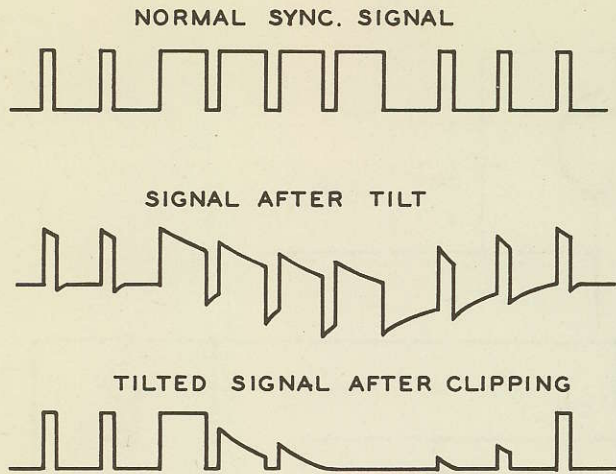

Figure 7A. Defect in Sync Separators

the charging capacitor, the remainder of the circuit is identical to its monochrome counterpart.

The multivibrator oscillator requires a change in the frequency controlling resistor, the resonating of the LC stabilizing circuit and a change in the charging capacitor.

Some possible sources of instability are:

1. Defective sync signals
2. Error in the time constants of the A-F-C circuits
3. Undesirable coupling between the oscillator and the output circuit

Many commercial sync separator circuits produce defective sync because of poor response to low frequencies. As shown in Fig. 7A, when the low frequency response is inadequate, the horizontal pulses are degraded during the vertical pulse and directly afterward. After the tilted signal is clipped, the horizontal pulses are reduced in amplitude or eliminated altogether at the top of the picture. If the horizontal AFC is efficient, horizontal hold may recover fully before vertical unblanking. The instability or steady side shift sometimes seen in the top of the raster is almost invariably due to performance inadequacies in the sync amplifiers and clippers.

When triode tubes are employed for sync clipping, video high frequencies have a tendency to leak through the grid-plate capacity and impair synchronization. A small shunt capacitor is occasionally used to bypass this unwanted video component; the value chosen should be small enough to prevent integration of the color sync pulses. If integration does occur, the

same undesirable signal distortion occurs as for differentiation.

The numerical value of the horizontal AFC time constants can be one half of that for monochrome because the horizontal sync rate is doubled.

When the receiver is a dual frequency type, the changeover switch introduces undesirable coupling between the oscillator and output circuit. The remedy is switch shielding and/or careful dressing of leads and components.

One of the design problems is the two-frequency horizontal output circuit. The output transformer is called upon to operate satisfactorily at both 15750 and 29160 cycles; the requirements to be met are:

1. Sufficient scan amplitude
2. Scan linearity
3. Flyback sufficiently rapid to be completed during horizontal blanking.
4. High voltage for conversion to DC by a rectifier
5. Filament power for high voltage rectifier

A comparison of the different scan times, retrace times, etc. establishes the relationship between the two modes of operation.

F _H	T _H	T _R	T _S	F _O (MIN)
15750	63.5 US	8.9 US	54.6 US	59 KC
29160	34.5 US	4.8 US	29.7 US	109 KC

$$F_0 = \frac{0.525}{T_R}$$

WHERE F₀ = RESONANT FREQUENCY OF TRANSFORMER AND YOKE

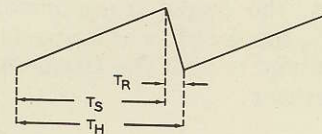
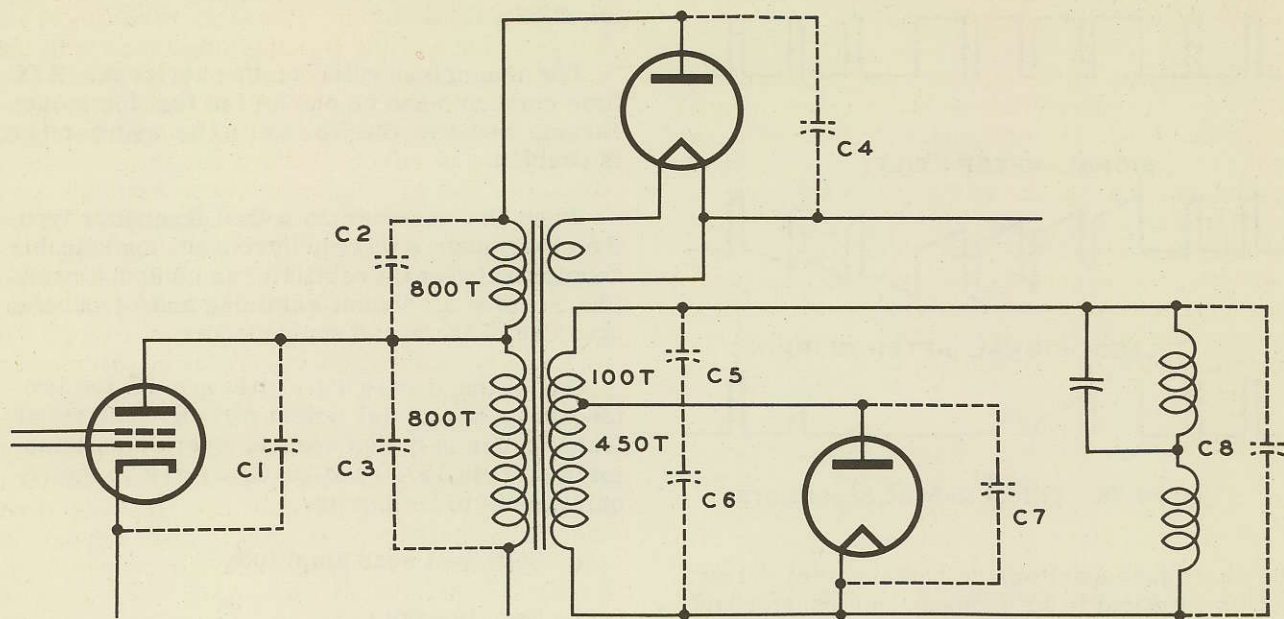

Figure 8. Color-Monochrome Comparison of Horizontal Times

The design of horizontal output circuits at 15750 cycles is well covered in the present day literature and only the special problems introduced by color need be mentioned.

The horizontal cycle consists of three parts: (a) the driver tube conducts and supplies power to the output circuit for more than 50% of the



C1 - DRIVER OUTPUT CAPACITY	10 MMF	C6 - DAMPER WINDING CAPACITY	30 MMF
C2 - HV WINDING DISTRIBUTED CAPACITY	48 MMF	C7 - DAMPER TUBE CAPACITY	15 MMF
C3 - PLATE WINDING DISTRIBUTED CAPACITY	30 MMF	C8 - YOKE CAPACITY	66 MMF
C4 - HIGH VOLTAGE RECTIFIER CAPACITY	4 MMF		
C5 - DISTRIBUTED CAPACITY BETWEEN 450 AND 550 TURNS OF SECONDARY	5 MMF		

All capacitance value in micromicro farads

Figure 9. Capacity Loading of Horizontal Output Transformer

horizontal period, (b) a half cycle of free oscillation during the flyback time and (c) the decaying magnetic field supplies energy to the output circuit.

The percentage of time during which the driver conducts is always greater than 50% and depends upon the circuit losses, i.e., the greater the losses, the longer the conduction time. The total amplitude is a function of the circuit losses which includes the driver tube losses, damper tube losses, the output transformer losses, the yoke losses, the high voltage losses and the energy required to heat the filaments of the high voltage rectifier.

During the flyback cycle, the output network acts as an open-circuit resonant LC circuit. Retrace time (t_r) depends upon the resonance frequency of the transformer yoke system. Excessive retrace time creates the condition of foldover at the left hand side of the picture. Conversely, insufficient retrace time is undesirable because high voltage regulation suffers and surge voltages increase. Shifting from the monochrome resonance frequency of 70 kc. to the color resonance frequency of 120 kc. is not difficult, but capacity reduction methods must

be effectively employed. Capacity loading is the most serious limiting factor in accomplishing operation at the higher frequency.

These capacities are transferred to the yoke in the customary reciprocal relation based on the square of the turns ratio:

$$\frac{N_c^2}{N_y^2} = \frac{C_y}{C}$$

In the example given, the transferred capacitance is 312 uuf. The 8 millihenry yoke and the 84 millihenry secondary in parallel are the circuit equivalent of an inductance of 7.2 millihenry. The calculated resonance frequency of the system is, therefore, 106.5 kc. The measured system resonance using a signal generator and voltmeter is 110.4 kc. When measuring transformer characteristics, it is necessary to apply an "artificial" core flux by the insertion of a d-c current through the windings. A few trial d-c currents, judiciously chosen, will indicate when the core flux density is sufficient to stabilize the ferrite core in both the transformer and the yoke.

The measured resonance value of 110.4 kc. is less than the theoretical value of 120 kc.; it

represents a good design compromise that does not penalize color performance.

An analysis of the system capacities indicates that the capacities across the greatest number of turns affects the resonance frequency to the largest degree. Keeping the turns ratio of the transformer at the smallest possible value minimizes the capacity effects. A voltage doubler increases the high voltage rectifier capacity, but decreases the distributed capacity of the high voltage winding by a greater amount for a given high voltage. If the voltage required exceeds 9 kv., a voltage doubler usually proves desirable.

Undue crowding of the high voltage and transformer compartment increases the stray capacities. Yoke design affects the circuit appreciably. Some of the newer anti-astigmatic yokes with overlapping horizontal and vertical windings, for example, are poor from the capacity-reduction standpoint.

Power requirements for 29160 cycle operation are greater than for 15750 cycle operation. Since $P = W f_h$ where W = reactive energy stored in magnetic field and is almost constant with the scan frequency f_h , the reactive power required of the yoke is almost an approximate linear function of the scan frequency. Eddy current and hysteresis losses normally increase with frequency. Transformer and yoke core losses are dependent upon the core material; a core made of the proper material in the proper manner can show greater efficiency on the higher color frequencies than on the lower monochrome frequencies. High efficiency, high permeability ceramic ferrite cores effect a substantial reduction in core losses at the higher frequencies. Ferrites are more easily saturated magnetically than powdered iron cores. Air gaps are usually used in the magnetic circuit to limit core saturation. Saturation is also a function of temperature; core temperatures should be held to the lowest practicable value by mounting the transformer remote from heat producing components such as tubes.

Copper losses of the transformer are determined by the d-c resistance of the wire and by its skin effect. The former varies with temperature; the latter is a function of frequency. Skin effect may become large at the higher harmonics of the wave-form and the retrace frequency. Litz wire instead of solid wire may show an improvement of circuit Q , but is ordinarily not worth the extra expense. Larger solid wire reduces copper losses, but simultaneously increases distributed capacity and leakage inductance. Although a 6BQ6GT tube delivers sufficient energy for monochrome circuits, a 6BG6G is necessary for color.

The transformer windings must be coupled as tightly as possible. Currents resulting from the resonance of the leakage inductance with the circuit capacitance feed into the deflection system and cause ripples at the beginning of the scan. These ripples are not to be confused with flyback dieout effects that are due to insufficient damping. Loose coupling between windings also decreases the power transfer capabilities of the transformer. Excessively tight winding configurations, however, increase distributed capacities, and usually reduce breakdown voltages. Air gaps used with ferrite cores to decrease saturation effects also decreased coil coupling.

A good solution for the coil coupling problem is the auto-transformer. Auto-transformers provide improved efficiency and fly-back time over the isolated type winding. Less copper is employed; this results in lower copper loss, smaller distributed capacity and greater coil coupling. The auto-transformer is not without its deficiencies, however.

An advantage of the iso-winding is that it provides the phase reversal necessary to operate the damper cathode at AC ground potential; whereas, the auto-transformer circuit requires operating the damper cathode at high AC potential. This results in two circuit impairments; (a) the damper heater supply must withstand a pulse potential of 1500 volts or more, and (b) since the damper cathode has a greater capacity to ground than the plate, fly-back time increases. With separate heater-cathode diodes, care must be taken to avoid exceeding the heater-cathode breakdown voltage. The heater is usually returned to an intermediate tap on the output transformer to limit the voltage to a reasonable value.

Until recently, another disadvantage of the auto-transformer was the difficulty of providing electrical centering. Figure 10 shows a circuit modification that accomplishes this.

Figure 10 also shows a practical dual frequency transformer design. It employs a voltage doubler, a 6BG6G driver and a 6BY7G damper tube. The total input is 34 watts, and it effectively scans a 70 degree tube with an accelerating potential of 15 KV. The core is ferrite with 15 mil air-gaps in both legs. The yoke is a standard RCA type design with ferrite core and 8.3 Mh winding.

A fixed turns ratio transformer cannot be expected to operate efficiently on two frequencies so far apart. Turns switching is accomplished in the secondary side of the transformer; the presence of a 3KV potential on the plate side precludes switching in the primary circuit. With

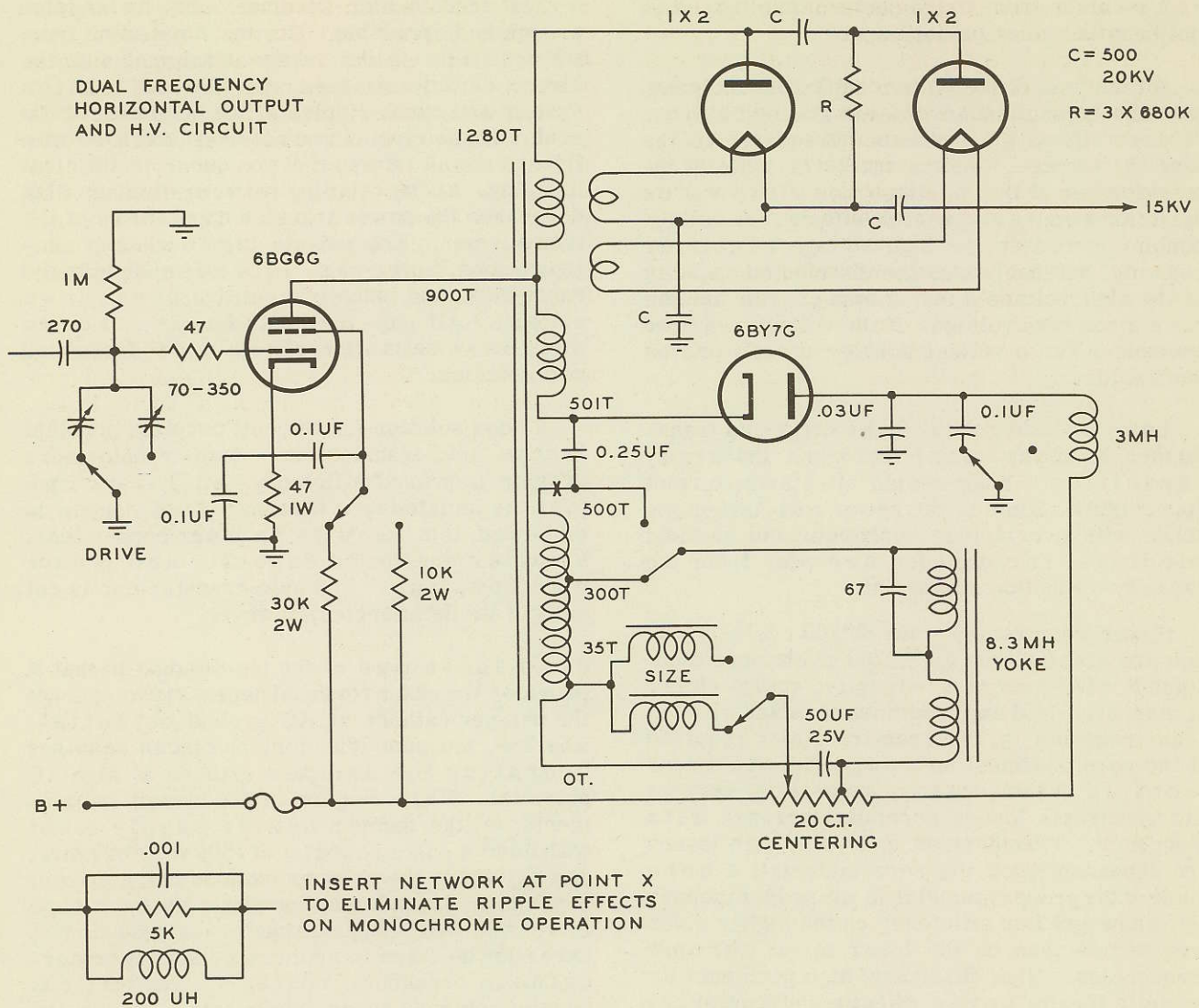

Figure 10. Dual Frequency Horizontal Circuit

a standard 8.3 Mh. deflection yoke coil, peak potentials of 1500 V. exist in the secondary circuit. At this potential, it is practicable to use conventional ceramic wafer switches. Make-before-break contacts are used to prevent a momentary open secondary, with its high voltage transient surges during the switchthrow. As an additional safety factor, two sets of contacts can be connected in series to increase the breakdown-voltage ratings.

The parallel inductance, capacity, resistance network in the 500 turn tap acts as a tuned trap to eliminate a monochrome deflection ripple. These ripples create the effect of white vertical bars at the left side of the raster.

Much work is yet to be done with the direct coupled yoke. The same sort of design problems found in monochrome operation are present in

color. An additional problem is that it is difficult to design an efficient high impedance yoke, with the desired low value of distributed capacity.

VERTICAL SCANNING

The dual frequency vertical system is switchable between 60 cycles and 144 cycles for color. Figure 11 shows a practical circuit that functions with a minimum of parts.

The vertical pulse integration network performs the function of vertical separation on both color and monochrome. For optimum results, the network time constant should be smaller for color than for monochrome. The added switching complication, however, is ordinarily not worth the slight increase of circuit efficiency; the feature is omitted in the interest of simplicity.

A common front panel hold control is used in conjunction with switched fixed resistors to set the approximate frequency. A separate vertical height control is necessary to compensate for the difference in generated sawtooth amplitude. Separate charging capacitors and peaking resistors are switched in for color. Although not completely necessary, separate linearity controls make for a more flexible adjustment.

Some vertical oscillation transformers have too low a free running frequency; oscillatory die-out may still be present at the vertical unblanking time. When the vertical oscillator is isolated from the horizontal sync takeoff point by only the vertical separator integration net-

work, the excessive vertical pulse may feed through and cross-modulate the horizontal sync timing. This results in a stationary distortion at the top of the raster, regardless of how the picture is rolled vertically. To correct this condition requires a transformer with a sufficiently high self-resonant frequency such that during color operation, the transformer will return to a passive state within the vertical blanking period. A good vertical output transformer designed for a 60 cycle circuit is usually satisfactory for 144 cycle operation.

A standard color picture has 405 lines as compared with the monochrome standard picture of 525 lines. Any line pairing due to faulty inter-

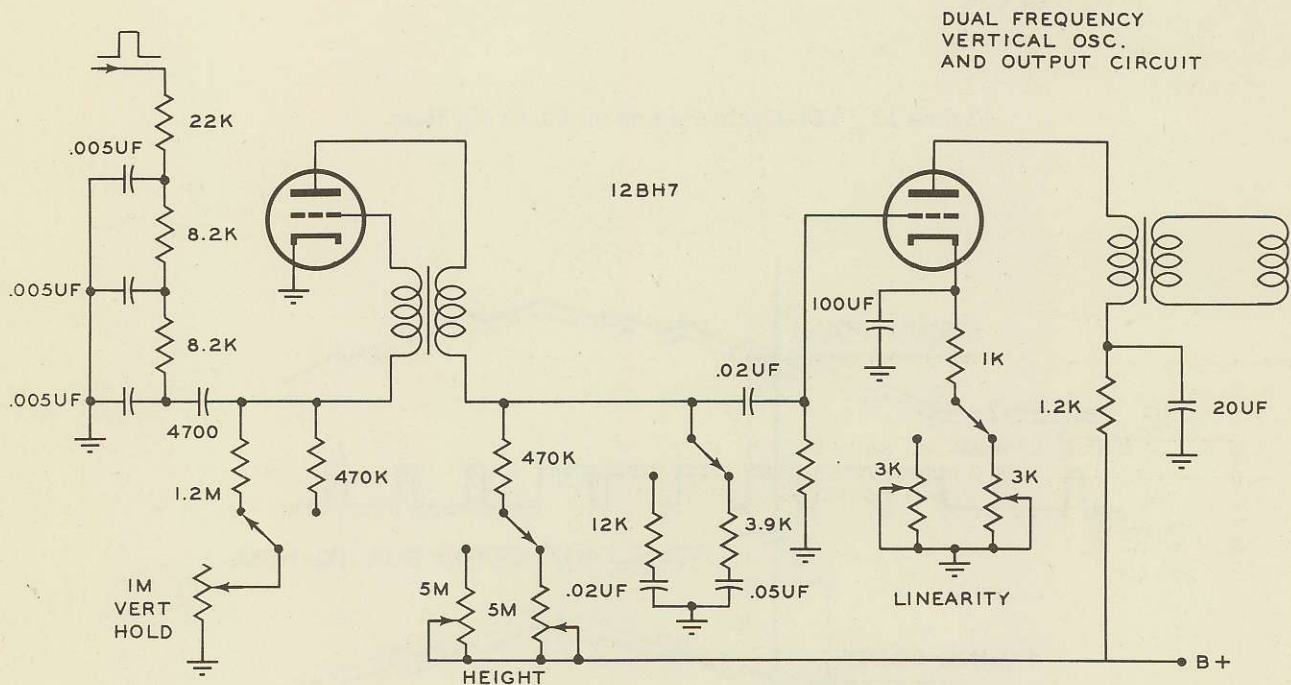

Figure 11. Dual Frequency Vertical Oscillator and Output

lace reduces the vertical resolution by a factor of up to two. The same methods used for obtaining good interlace in monochrome can be used for color. When a single-gang switch is employed for frequency changeover on both the vertical and the horizontal scans, care must be taken to shield the two from each other. Contrary to recent commercial practice, it is still highly desirable both for color and monochrome to shield the horizontal output circuit completely.

HUM

Sixty cycle hum voltages can creep into a television signal both at the transmitter, and at the receiver. Hum degrades the television

signal both in monochrome and color but in slightly different ways.

Sixty cycle hum in the Z axis of a monochrome signal introduces a wide horizontal hum bar into the picture. If the hum and signal are exactly locked in frequency, the hum bar remains stationary and attracts but little attention unless it is of high amplitude. In the case of non-locked hum and signal, the hum bars move slowly up or down with the beat note and are more objectionable for a given hum amplitude than are stationary bars.

Another degrading phenomenon due to hum is the tendency for the horizontal deflection to be

$$E = A \sin \theta + e$$

WHERE:

- E = INSTANTANEOUS PULSE VOLTAGE
- A = MAX. PEAK HUM VOLTAGE
- e = PULSE AMPLITUDE
- θ = INSTANTANEOUS HUM ANGLE

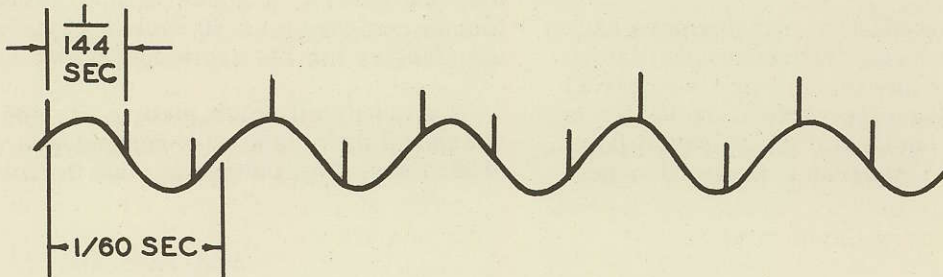

Figure 12. 144-Cycle Pulses on 60-Cycle Hum

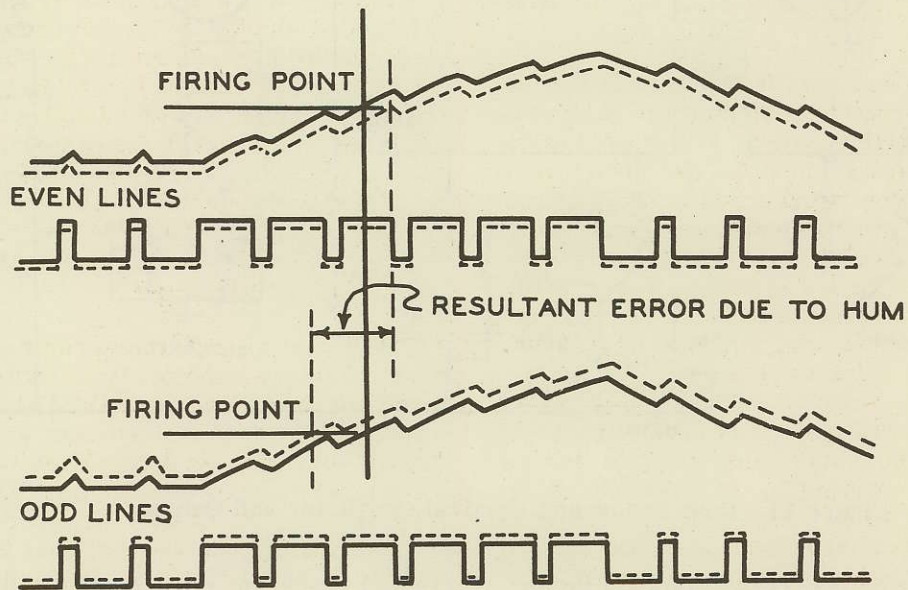

Figure 13. 60-Cycle Hum in Vertical Resulting in Mistiming

shifted sidwise. Hum due to a non-synchronous mains supply causes the vertical axis of the picture to weave back and forth at a beat note rate. When such phenomena are observed, the receiver may not be at fault because these effects can originate at the television transmission terminal. If the hum originates in the receiver, it usually arises from inadequate power supply filtering, strong transformer AC fields or other like source. These will be discussed later.

One advantage of a 60-field monochrome signal is that hum does not impair scanning interlace. Strong hum fields will cause large values of distortion of picture geometry before interlace becomes noticeably impaired.

Sixty cycle hum on the Z axis of a 144 field picture shows up as visual flutter. The term flutter is used to differentiate the phenomenon from system flicker which is a primary system restriction determined by the number of color

frames per second. When only one or two colors are being reproduced, the 48 cycle color frequency beats against the 60 cycle hum and causes a flutter rate of 12 cycles. A picture of three equal color component amplitudes is fairly resistant to 60 cycle hum because the fundamental beat between 60 and 144 cycles is 84 cycles, a value too high to be observed at normal picture brightness. A beat between the power supply 120 cycle ripple and the 144 cycle field rate, however, gives rise to a noticeable form of 24 cycle flutter.

Hum that causes a sidewise weave of a 60 field picture will cause a fast jitter of a 144 field picture. The jitter may or may not be more objectionable than the weave; this depends upon the preference of the observer.

Interlace in the 144 field picture can suffer degradation from large 60 cycle hum voltages.

Figure 12 illustrates a series injected 60 cycle hum. An integrating vertical pulse separator synchronizes a blocking oscillator in the usual fashion. Figure 13 shows the constantly changing vertical timing that results from this condition.

Upon further analysis it can be seen that the lines will alternately interlace and pair, producing an interline jitter. If the eyes of the observer are focused on the line structure, a slow upward or downward crawl is observed. In one respect this jittering interlace is preferable to complete stationary line-pairing because the line structure is less visible. The interline jitter we have just discussed is purely a geometric configuration, and is not to be confused with an interline color crawl.

The same type of interlace deficiency can result from the hum being inserted into the vertical oscillator, resulting in a periodic shifting of the firing point. Figure 13 can be modified to show this phenomenon when the vertical sync input is constant, but the oscillator firing point is made to vary at the 60 cycle rate.

The previous examples have considered only series hum. In the case of amplitude modulated hum, a different set of conditions arise. When the entire composite video-sync signal is cross modulated by 60 cycle hum, the composite signal may be considered as the carrier and the hum as the modulation frequency. The carrier is exceedingly complex because its frequency content varies between 48 cycles and the highest video frequency, usually four megacycles.

The usual clamper or D.C. restorer can remove the series hum but cannot remove the amplitude modulated type.

For small percentages of modulation, the average axis is not appreciably affected while the signal tips receive the full amplitude variation. The average axis varies with picture content, and is usually slightly above the black level. Hum in this case affects the sync tips and video white region while having negligible effect in the black region.

Different types of sync strippers remove varying amounts of hum depending on the clamping action and whether both ends of the sync are clipped. Any hum modulation of the sync after stripping causes the sync to vary at 60 cycle rate once again. It is safe to assume that regardless of whether the hum modulates the sync tips, black level or both, the result is vertical mis-timing.

Because of the trapezoidal nature of the horizontal sync pulse, severe hum modulation may also affect horizontal timing with a resultant side jitter. Vertical interlace, however, will be impaired long before degradation shows up in the horizontal sync.

External 60 cycle fields acting directly on the kinescope and its deflection coils impair interlace, and to a much smaller degree, produce flutter and side jitter. In a 60 field monochrome receiver, such external fields (if synchronized with the signal) act in the same direction for each vertical. Therefore, at worst, the result is a slight decentering of the entire raster. In the 144 field receiver, the hum flux de-centers the vertical fields with an ever changing polarity and magnitude.

Designing a color television receiver with good interlace and low visual flutter qualities is not difficult if certain principles are kept in mind. Sources of disturbances are either electrical, magnetic or both. When watching a picture that has poor interlace, determine whether the lines are steadily paired or jittering. If steadily paired, use conventional techniques for obtaining good interlace. If the lines jitter and a slow upward or downward crawl is visible, the cause is 60 cycle interference. Stop the motor and see if the trouble clears up. If not, test the receiver on a 144 cycle mains supply, this should eliminate all 60 cycle components. A 144 cycle mains supply can be made by multiplying the 60 cycles to 720, dividing to 144 cycles and driving a tuned, high powered, Class "C" amplifier.

When the trouble has been proved definitely to be caused by 60 cycles, try operating the tube heaters on a storage battery. Balanced heaters with grounded center tap eliminates any 60 cycle chassis currents; this corrective measure is usually effective.

Inadequate power supply filtering or unbalanced rectification can cause sufficient hum to affect sensitive circuits. The power supply filter normally need not be any larger than that found in most good monochrome designs. Heater-cathode leakage in tubes used with their cathodes above ground with respect to the signal is another source of trouble.

The most prevalent trouble, however, is the stray magnetic flux from the power transformer acting upon the kinescope proper. Physically separating the transformer from the tube will prove if this is the case. The larger floor model receiver allows for greater separation between these components than the table model receiver. With a well shielded motor it is possible to dispense with extra shielding. A heat-treated Mu-metal kinescope shield is a certain cure-all but is costly. Partial shielding in the form of flat plates of less expensive shielding material placed in strategic positions may prove to be an effective solution at low cost.

Power transformer design has a marked effect on the magnitude of flux leakage. Overloaded or skimpy transformers with their large core flux densities should be avoided. If possible, the transformer should be designed without any external gaps; one successful design employs the outer side of the lamination punched as one piece. The customary copper strap is also advantageous.

Hum bucking experiments have been tried but their effectiveness is doubtful because of the difficulty of maintaining proper bucking amplitude and phase relationships. Rotating the power transformer, disk synchronizing saturable reactor, and motor for a magnetic null, however, if effective and can be recommended as worth while.

A SUMMARY OF POSSIBLE PICTURE DEFECTS AND THEIR CAUSES

Horizontal Jitter

1. Sixty cycle hum voltage in sync causes the horizontal pulses to be modulated at the sixty cycle rate. This beats against the 144 cycle field rate and gives rise to an eighty-four cycle side jitter. If only one color is being transmitted, the sixty cycle hum beats with the forty-eight cycle color field rate which results in a twelve cycle side jitter.
2. Power supply 120 cycle ripple in the sync creates the same condition as in 1. except that now the beat with 144 cycle field rate causes a twenty-four cycle side

jitter. The forty-eight cycle color field rate beats against the 120 cycle ripple and gives rise to a seventy-two cycle side jitter.

3. Sixty cycle magnetic fields acting directly on the kinescope causes an eighty-four cycle side jitter by beating with the 144 cycle field rate. If only one color is being transmitted, the resultant is a twelve cycle jitter.
4. Incorrect horizontal A.F.C. time constants cause unstable horizontal locking. The nearly double line rate of 29160 cycles allows this time constant to be one-half that necessary for monochrome. Too long a time constant prevents the receiver from following normal variations in transmitter sync timing.

Vertical Jitter and Poor Interlace

1. Sixty cycle hum in sync or in vertical oscillator beats with the 144 cycle vertical rate to produce an eighty-four cycle vertical interline jitter.
2. Sixty cycle magnetic fields from the motor and, or, the power transformer acting directly upon the kinescope produces an eighty-four cycle interline jitter.
3. Poor interlace is characterized by either steady pairing or interline jitter. The steady pairing is usually caused by the same deficiencies that are found in monochrome television such as horizontal pulses in the vertical circuits, poor sync separation, etc. Interline jitter is caused by the factors mentioned in one and two.

Flicker and Flutter

1. Flicker is defined as the visible 48 cycle flicker apparent when a single color field is above a certain highlight brightness. Flicker is, therefore, a system limitation beyond the control of the receiver designer except as he may employ special techniques such as long persistence phosphors.

Flutter is a flicker caused by extraneous conditions external to the basic color system.

2. Sixty cycle hum in the video introduces a variety of flutter frequencies, the most visible of which is twelve cycles. This is the beat between the sixty cycle hum and the forty-eight cycle color field rate.
3. Power supply 120 cycle ripple beats against the 144 cycle field rate and produces a twenty-four cycle flutter. The eye is less sensitive to twenty-four cycle flutter than to twelve cycle flutter.
4. A twenty-four cycle flutter is created when a six segment disk employs color filters with uneven light transmission. The two opposite green filters should be matched in light transmission within one or two percent
5. Uneven dirt distribution on the disk gives rise to flutter by unbalancing the light transmission qualities.
6. Mechanical disk vibration transmitted to a sensitive video, IF or RF stage causes flutter.
7. Erratic color flashes are caused by high voltage corona discharges.
8. Erratic color flashes are also caused by static discharges from an unbonded mechanical disk unit.

Misregistration and Color Fringing

1. One or more color images displaced horizontally. The usual cause is a defective sync separation circuit that is video level sensitive. The varying field amplitudes results in a clipping differential that causes the horizontal sync pulses to be displaced.
2. Kinescope magnetic deflection sensitivity varies inversely as the square root of the high voltage applied to the second anode. If the high voltage supply has poor regulation, the picture size varies with kinescope beam current. Adjacent fields of different levels affects the high voltage with the resultant raster size change and produces color misregistration.
3. Static electrical charges are built up between the revolving plastic disk and the

kinescope tube face. Non-aluminized kinescope cannot dissipate these charges which cause picture decentering. If the revolving disk is slightly warped, the spacing between the disk and the tube face is constantly changing. The resulting oscillating electrical charge causes the raster positioning to oscillate likewise. This condition is avoided by employing aluminized tubes or coating the disk and tube face with an anti-static solution.

4. If mechanical vibrations from the revolving disk is transmitted to a sensitive circuit, color misregistration can be produced. These vibrations emanating from a synchronized disk are in synchronism with the picture field rate. It is this that causes a color misregistration rather than just a jitter.

Color Shading

1. The picture may contain a vertical or horizontal brightness shading. If shading is discernable, check the dc restoration at the kinescope. Horizontal shading is also caused by an insufficient coupling time constant to the kinescope which results in a horizontal tilt.
2. The picture may contain a vertical color differential. Here the cause may be poor video amplifier low frequency response. It is important to remember that when the adjacent fields are of different amplitudes a forty-eight cycle component is present. If the video amplifier causes a low frequency waveform tilt, uneven amplification results in a vertical color shading.
3. Incorrect positioning of the kinescope behind the revolving disk causes uneven color distribution. Since the phosphor decay is finite, it is important that the lingering phosphorescence be covered by the given color filter for a predetermined period. Locating the raster at the correct position, as per the disk manufacturer's instructions, should avoid this condition.

THE CBS-COLUMBIA COLOR COMPANION RECEIVER

by

Edward M. Noll

The companion color receiver presents an easy method of adding color to a present receiver. Such a unit although driven from the standard monochrome receiver can be positioned on top of, beneath or to the side of present receiver. With proper length of cable it can be located some distance away in another section of the room. It has its own picture tube and color scanning assembly that operates separately from picture tube of receiver to which it is attached. Standard receiver is used for monochrome reception; companion unit, for color viewing.

Such an arrangement means extensive work must not be performed on receiver---no rewiring, parts re-arrangement, or change of cabinet design. It should be possible to attach a companion unit and have it in operation less than a half-hour after delivery.

The color companion unit consists of video amplifier and picture tube, sync separator and amplifiers, vertical and horizontal deflection systems, motor control circuits, motor and color wheel, (or possible a drum) and self-contained power supply. Companion unit attaches into video amplifier system of monochrome receiver. Generally input video amplifier tube is removed and an adapter plug is inserted into its socket. Tube is then plugged into adapter. Leads from the adapter are connected to companion color receiver and serve as a means of supplying a composite video signal to companion circuits. Plan is ideal because color addition can be made without depriving customer of television and without altering their present receiver. Color companion can be positioned near monochrome receiver or, for a more balanced appearance, at some other position in the living room or den. It is quite feasible to locate color companion in an adjacent room when a multiple speaker arrangement is used for the sound portion of the telecast.

Preferably steps should be taken to darken picture tube of monochrome receiver when color viewing is desired. This can be accomplished with phono switch on many receivers or, simply instruct customer to turn down receiver brightness when color observation is desired.

A number of advantages of the companion are apparent---ease of installation, neatness, well-planned cabinet design, and non-interruption of regular television service.

The CBS-Columbia companion color receiver is shown schematically. It contains 18 tubes plus picture tube---3 tube video amplifier, 2 tube sync separator and amplifier, 8 tube deflection system, and 5 tube motor control and power supply. A composite video signal is taken from input video amplifier of receiver and applied to video input of companion color receiver. Input video amplifier V1 is used or is not used depending on polarity of composite video signal at point it is removed from monochrome receiver. A sync negative composite signal is needed at grid of second section to obtain proper polarity at grid of picture tube and at sync separator. If sync is positive at point of removal it is first passed through first section of video tube V1 (gain is approximately unity) to reverse its polarity, arriving at grid of second section with sync negative.

Signal is increased in level by a two stage video amplifier, tubes V1 and V2, and is applied to grid of picture tube. Brightness restoration is established by V3. Series-shunt peaking is used with first video amplifier stage giving good high frequency emphasis. Low frequency response is retained by long time constant grid coupling circuits and large value cathode capacitors. Contrast (peak-to-peak signal amplitude) is set by bias potentiometer in cathode circuit of first video stage.

Composite television signal with sync negative is also applied to three stage sync amplifier and separator (tubes V7 and V8) from input switch. Sync separator tube V8 has a long grid time constant and low screen voltage. It drives portions of composite television signal lower than blanking level beyond cut-off. Thus negative composite sync develops at its plate circuit. A strong sync signal is delivered to following integrator circuit. Horizontal and vertical sync components separate at output of sync amplifier---vertical component is removed by integrator and used to synchronize vertical blocking oscillator V9; horizontals are applied



Figure 14B. CBS-Columbia Color Companion Receiver, Front

Figure 14C. CBS-Columbia Color Companion Receiver, Rear

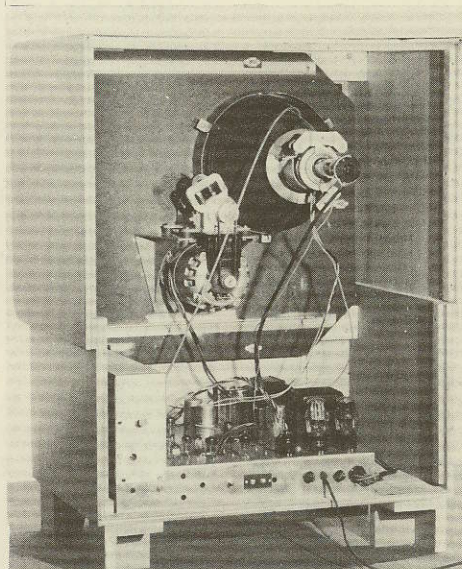
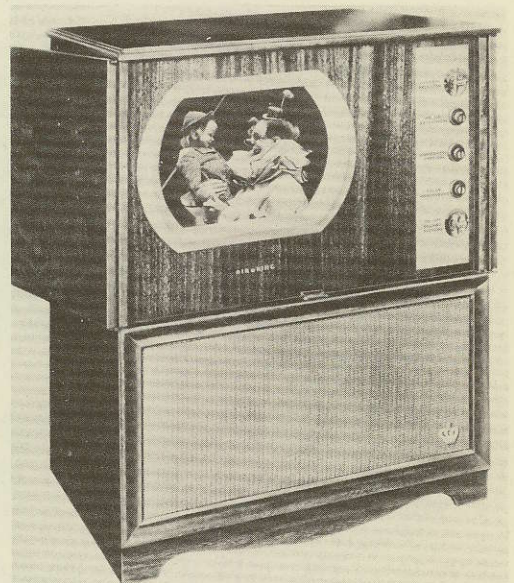

Figure 14D. CBS-Columbia Combination Monochrome and Color Receiver



to phase detector type of horizontal sync control V12. To obtain proper pulses to drive horizontal circuit both plate and cathode outputs are employed from final sync amplifier. Consequently, equal-amplitude but opposite-polarity pulses are obtained across the like value 2.7K resistors in plate and cathode. Vertical integrator time constant is of suitable value to integrate effectively the shorter vertical sync interval used at color field rates.

Blocking oscillator circuit is conventional, developing correctly modified sawtooth across 0.02 mfd.-22K combination in plate circuit. Vertical output circuit is straight-forward with an additional signal being taken off its plate through a 0.001 mfd. capacitor for application to motor control circuit.

Horizontal phase detector circuit compares relative phase of arriving horizontal sync pulses with a sawtooth fed back from secondary of horizontal output transformer. A pulse waveform is really present across secondary of horizontal output transformer but is integrated into a sawtooth by the two series 100K resistors and .002 capacitor at low side of phase detector circuit. Any unbalance in the diode currents as caused by a phase shift between sync and fed-back voltage, changes d.c. charge on 0.001 mfd. capacitor on grid 2 of horizontal oscillator V13.

Oscillator is a stabilized and cathode-coupled multivibrator (29,160 tuned circuit in plate of first section). Frequency is determined by grid time constants and d.c. bias on grid of first section. A compensating shift in bias and frequency is made whenever phase displacement occurs.

Horizontal output tube V14 supplies deflection energy to horizontal coils and damping (tube V18) system. Retrace transient pulse is applied to rectifiers (V15-16-17) of voltage tripler circuit. A 15,000 volt anode potential is developed for picture tube. Deflection output circuit and resonant frequency has been properly designed (output transformer and loading) to obtain the necessary faster trace and retrace times needed at color line rates of 29,160. Voltage boost voltage is applied to plate of horizontal output tube and vertical sawtooth forming circuit.

A three circuit motor control system is used. It receives its synchronizing signal in form of a

positive pulse from plate of vertical output tube V9. At plate of vertical output a negative sawtooth is present but the retrace includes a sharp positive pulse transient. It is this positive pulse that is used to operate the motor control system in synchronism with received vertical timing (received vertical sync pulses determine frequency and phase of vertical output signal.) The phase detector V5 compares phase of vertical output pulse (frequency and phase follows that of vertical sync transmitted from station) with that of a sinewave formed by a small 6 pole generator attached to motor shaft. Motor rotation has proper speed (when synchronized) to drive alternator and generate a 144 cycle sine-wave. This can be compared with the 144 cycle pulse from the vertical output tube.

Any differential caused by an attempted shift in phase of motor or arriving signal relative to each other causes a momentary unbalance in the phase detector circuit. There is a resultant shift in the relative triode currents and d.c. charge on 0.01 output capacitor changes. Charge on this capacitor acts as bias for the motor control tube V6. When bias is shifted the d.c. plate current of motor control does likewise. Such a shift in current in the primary winding of the saturable reactor alters the amount of core saturation and, therefore, the secondary inductance. This inductance is in series with motor windings and a.c. line and any change will cause motor to speed up or slow down. This in turn changes frequency of signal generated by alternator, which signal feeds back to phase detector. Thus in a short interval, two signals (one from alternator and one from vertical output tube) will zero in phase detector and motor will sync-in with vertical timing. This arrangement keeps camera and receiver motors locked in frequency and phase.

A push-button switch permits temporary shorting of the secondary of the saturable reactor to permit momentary speed-up of motor when phasing filter colors. This is done when station is first tuned in---red filter must be in position at receiver at same instant red signal arrives so colors will be viewed in same order they were scanned at transmitter.

A well-designed and well-filtered power supply is incorporated in companion unit to supply necessary anode and bias voltages for operation of circuits with a minimum amount of ripple and feed back.

THE TELE-TONE COLOR COMPANION RECEIVER

by

Elias Cohen

Tele-Tone Radio Corp.
New York City

and

Allan Easton

Manager
Communications Engineering Division
Radio Receptor Company, Inc.

Courtesy Electronics Magazine

The F.C.C. decision which approved the C.B.S. field-sequential system of color television presented to the authors the problem of how best to meet the inevitable demand for a commercial device which, operating in conjunction with already existing black-and-white receivers, would produce good color reception from stations transmitting programs in color. The companion color unit was to bridge the gap between standard monochrome and the new field-sequential color television until there developed sufficient economic justification for complete color or color and black-and-white receivers. In this manner the consumer was protected against complete obsolescence of his monochrome equipment and at the same time could purchase the means of securing color television.

General Requirements

Several requirements suggest themselves for a system utilizing existing monochrome receivers for production of color pictures.

1) Ease of installation is of great importance. Any complex reworking or rewiring necessary in the monochrome set as handled by a service group would result in non-uniformity of performance between receivers on both monochrome and color operation.

2) When the color adjuncts are connected no appreciable deterioration of performance in standard black-and-white reception should be discernible.

3) The device should operate well and interconnect easily with most types and makes of commercial television receivers.

4) There should be no detraction in physical appearance of the television set. The device itself should meet the usual appearance standards set up for TV receivers.

Types of Systems

The first system considered, the adaptor-converter combination, did not meet these self-imposed requirements. The adaptor is a unit which when used in conjunction with the monochrome receiver, permits reception of color programs in black-and-white only. The converter is second unit consisting of motor, lens, and color disc which transposes the monochrome, field-sequential display into a full color picture.

The main advantages of this system are:

1) Economy - A minimum of additional parts is used. The monochrome circuitry performs double duty wherever possible and color operation is obtained by means of switching.

2) The same kinescope is utilized for both monochrome and color operation.

The disadvantages of this system are:

1) Installation may be a complex servicing job varying considerably from one type receiver

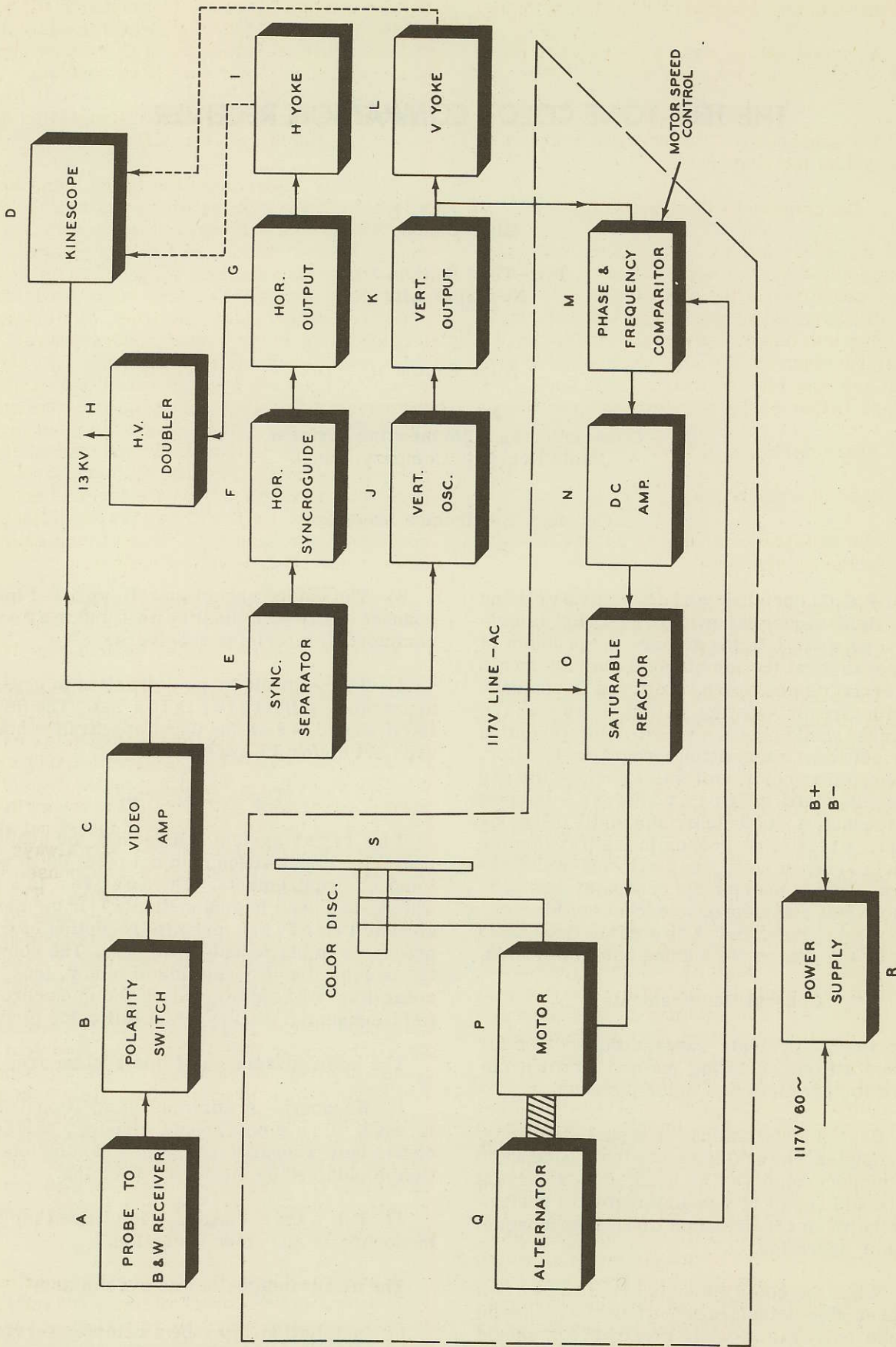

Figure 15. Block Diagram of Telecolor Unit

to another. Approximately one dozen circuits or circuit elements are involved in the switching.

2) At present it is extremely difficult to handle kinescopes larger than 12 1/2 in. by this system.

3) The appearance of the receiver is definitely affected by the conversion.

Description of Companion Unit

The standards set by management and engineering pointed out the necessity for a universal package converter of the slave type. This would be a self-contained cabinet enclosed unit which would plug into one of the tube sockets in the existing receiver by means of an adaptor plug without any chassis reworking. This could be a customer rather than a serviceman operation.

The characteristics of this system are:

1) Ease of installation.

2) The appearance of the cabinet is unaffected by the conversion.

3) The size of the kinescope for color is independent of the size and type of kinescope used in black-and-white operation.

4) The slave converter will work in conjunction with practically every television set on the market today.

Refer to Figure 15. The slave converter receives a source of composite video signal from the black-and-white receiver through the interconnecting cable and by means of the necessary circuitry including power supply.

The signal is amplified in a two stage video amplifier system (C) and is applied to the kinescope grid (D). A polarity switch (B) in the input circuit accounts for the difference in signal polarity that exists in some monochrome receivers. Part of the output of the video amplifier is fed in a conventional manner to the sync separator circuitry (E) which in turn feeds a syncguide type horizontal oscillator (F) at 29,160 cycles/sec. and an impulse triggered vertical oscillator (J) at 144 cycles/sec., which in turn drives the output circuitry (I and L). A flyback high voltage system (H) is used with a voltage doubler to supply the high voltage. The color discs are turned by a speed controlled, induction motor (P). The speed control circuitry consists of a balanced phase and frequency comparator (M) which compares the sine wave output of a six-pole alternator (Q) mechanically coupled to the motor with pulses derived from

the vertical output circuitry (K). The control voltage is amplified in a D.C. amplifier (N) which varies the inductance of a saturable reactor (O) and which in turn varies the A.C. voltage applied to the induction motor for speed control.

Description of System and Connection to Black-and-White Receiver

The only interconnection to the monochrome receiver is a probe which fits into the video tube socket of the black-and-white receiver and into which the video tube itself is plugged. The probe contains a cathode loaded stage which picks off composite video signal to drive the slave converter video amplifier with negligible loading effect to the monochrome receiver. The color receiver has neither tuner nor I.F. stages. It is called a slave type because it depends for its source of composite video signal on the monochrome receiver. Thus, when the monochrome set is tuned to normal monochrome transmissions they will appear as always on the black-and-white receiver, whereas when the tuner is set for a color transmission it will be viewed on the slave converter. The sound of course always emanates from the black-and-white receiver.

Breakdown of Circuitry

A. - The Video Amplifier System Fig. 16.

The video requirements while similar to that of a monochrome design are definitely more exacting. Since the composite signal derived from the black-and-white receiver could be either positive or negative depending on the type of receiver, provisions had to be made for switching circuitry so that the polarity of the signal at the color converter kinescope grid was always sync negative. The gain and frequency responses were to be independent of switch setting. The high frequency response was to be 4 Mc wide so that the geometric resolution would be as good as the I.F. response of the black-and-white receiver would allow. A rising characteristic is also desirable to obtain some video overshoot to add crispness to the picture and to compensate for the slight smear present in the transient response of many I.F. systems. The low frequency response has to be approximately 3 db at 48 cycles/sec. which is the primary color rate. Poor low frequency response will result in misrepresentation of the background color tones in the different frames, whereas in monochrome reception it would only result in a slight shading from top to bottom of the picture.

It was considered that a gain of approximately 70 with a drive of approximately 100 volts peak to peak was necessary to have sufficient reserve drive for the 10FP4 kinescope under all condi-

tions of operation. Another aspect to be closely watched in the video system was amplitude distortion which would give rise to color distortion, since different colors are transmitted during different frames and any compression of levels would affect one color more than the others.

Thus, the amplifier has to be substantially linear over its entire range of operation, unlike monochrome reception where non-linearity is often introduced in order to obtain a more pleasing ratio between average and peak brightness at high contrast settings. Since the majority of present black-and-white receivers have inter-carrier sound, provisions have to be made to have good 4.5 Mc. rejection before the cathode ray grid so as to avoid the fine beat affect which would be caused by excessive 4.5 Mc. signal on the kinescope grid.

Figure 16 indicates a simple way in which polarity switching is accomplished. The first video amplifier is either cathode or grid coupled depending on the input polarity. For most installations the tube will be grid coupled because a majority of the black-and-white television sets in use and being built today have their video detector so arranged as to yield a composite video signal with sync tips negative. Contrast variation is accomplished by means of a degenerative control in the cathode of the first video amplifier. The first video is half of a high gain triode 12AT7 tube, and the second video is a beam power output 6AQ5 tube to provide sufficient drive and linear operation. Good frequency response is provided for by the 2 section constant K filter in the first video stage and a combination of series and shunt peaking in the second video stage. Good low frequency response is accomplished by means of the low frequency RC boost network in the first video, and the use of 0.1 uf coupling condensers as well as the maximum possible grid leak resistors wherever possible.

The background control varies the negative D.C. voltage to which the D.C. restorer diode plate is returned.

The 2 stage system is linear, has a gain of approximately 70, provides 100 volts peak to peak drive at a bandwidth of 48 cycles - 4 Mc and has provisions to supply D.C. restored signal of negative polarity to the kinescope grid for either polarity input to the system.

B. - Sync Separator

The sync separator requirements are similar to those in monochrome reception, and the type of separator used (refer to Fig. 17) is

a fast-time constant cathode follower type, where a separate diode is utilized to keep sync tips at ground level. This is a standard type and need not be discussed further. There is a definite need for better noise immunity in the color system than in black-and-white transmission. Loss of horizontal synchronization for a few lines is more noticeable than in monochrome transmission because the tearout will appear in the color of the frame during which it occurs. Loss of vertical synchronization is extremely bad, because unless the recovery time is faster than the inertia of the speed control circuit, the color disc will also go out of synchronization.

C. - Vertical Deflection

The frame rate which is the frequency at which the kinescope face is scanned vertically, is 144 cycles/sec. Vertical retrace must be accomplished in 0.05 of a field which is approximately 350 usec. This is approximately 40% of the time allotted in monochrome transmission. The self-resonant frequency of vertical output transformers and yoke circuitry now used for monochrome receivers is good enough to permit direct conversion to the new frequencies. (Fig. 17)

A 53° - 50 mh vertical yoke is used. The yoke impedance being mainly resistive, the same output transformer can be used to match the yoke to the double-triode 6SN7 vertical output tube with very little loss in efficiency. Refer to Fig. 33. A single triode blocking oscillator is used in the usual manner to act as a combined vertical oscillator and discharge tube. The transition to 144 cycles permits a decrease in plate-time constant to give the necessary drive for the output tube without any loss in linearity. The percentage of step to sawtooth is larger in color operation necessitating a larger step resistor in series with the discharge condenser. The reason for this is apparent when one realizes that the purpose of the additional step to the sawtooth grid drive is to compensate for the voltage drop across the inductive portion of the yoke. The retrace time being much faster than before will cause the voltage drop L^{di}/dt to be larger.

The problem of interlace is basically a 30 cycle phenomena in monochrome transmission and is therefore relatively unaffected by 60 or 120 cycles power supply and line hum because of its harmonic nature.

In color transmission interlace is basically a 72 cycle phenomena and is easily deteriorated by 60 and 120 cycle hum. Sixty cycle hum for example will cause the pattern to go in and out of interlace at a 12 cycle rate. It is extremely important that the integrated vertical sync pulse

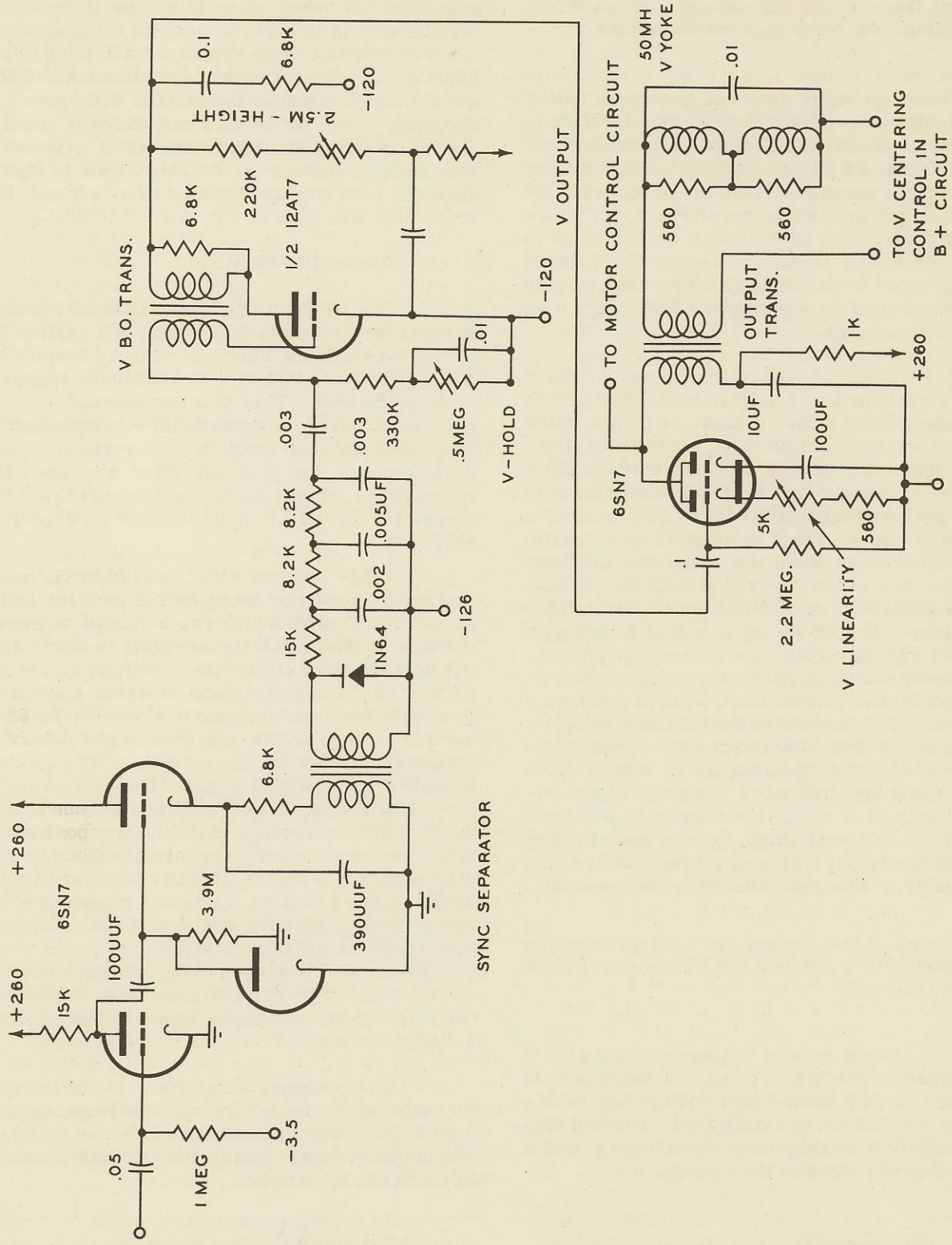

Figure 17. Sync Separator & Vertical Deflection Circuit

be free of all hum voltages. As will be noted in Fig. 16, the output of the sync separator is transformer coupled to the integrating pads to remove the hum voltages from the negative supply. Care must be taken so that the power line leads or filament leads do not come too close to the vertical oscillator circuitry.

The usual care must be taken to remove all horizontal pickup from the vertical oscillator circuitry. This can be helped considerably in the chassis layout by putting the vertical oscillator as far as possible from horizontal oscillator and output circuitry.

The major problem in the vertical circuitry seems to be to obtain good interlace rather than that of height and linearity.

D. - Horizontal Deflection & High Voltages

The horizontal scanning rate is 29,160 cycles/sec. (405 horizontal lines interlaced every two frames). This is almost twice the rate used in monochrome transmission. The maximum retrace time allowable is 0.14 H where H is the period of the horizontal scan. This figure is the minimum value that the width of horizontal sync pulse plus back porch may fall to. This calls for a maximum retrace time of 5 u sec. as against almost 10 u sec. in monochrome transmission. The losses in the yoke and transformer which are a function of frequency such as hysteresis and eddy-currents tend to cut down the efficiency at this new frequency. A high voltage of 13KV is desirable which in conjunction with a 10FP4 - 53° aluminum backed tube produces sufficient light output in spite of the light losses in the color disc and lens.

The horizontal synchroguide has to be readjusted to operate at the new frequencies and the capacitor across the stabilizing coil is set so it too can operate at the new frequencies.

To improve the retrace time, the horizontal output transformer has much less than the customary number of turns on the high voltage winding. To make up for the loss in high voltage a voltage doubler using two 1B3's, is used. (Refer to Fig. 18) The use of an auto-transformer permits more high voltage and subsequently less retrace time as the secondary winding is now in series with the primary, and H.V. winding to drive the H.V. rectifiers. A device borrowed from the CBS engineering department was to A.C. couple the secondary winding to the primary with the yoke being returned to the low side and the damper tube being returned to the high side. This is in order that we may have electrical centering which normally is not feasible in an auto-transformer type of

system. The filament of the 6W4 is connected through a resistor to the boost voltage. The cathode-to-heater rating of this tube for pulses as well as for inverse peak plate to cathode voltages allows safe operation of the circuit.

Horizontal centering is accomplished by a 50 ohm control which varies the amount of B plus current which goes through the yoke. A tapped potentiometer is used so that this control is bidirectional. The potentiometer is bypassed so as not to change the Q of the yoke or to feed horizontal lock into the B plus circuit.

The power input to the horizontal output 6BG6 tube (370 volts at 70 mils) is 33 watts and is not proposed as the most efficient method of scanning a 53° degree tube operating at 13KV. It does, however, give good linearity, good retrace time, plenty of width and a high voltage of 13KV with a regulation of 500 volts/100 u amps.

The yoke used is a 53° - 8.3 mh type with a powdered iron core.

D. - Power Supplies

The power supply (Fig. 18) design problem is no different generally from that existing in normal monochrome receivers except for the fact that the maximum allowable ripple voltage on the B plus supply must be severely restricted. The hum voltages whether 60 or 120 cycles are, of course, extremely harmful because of the non-synchronous relationship between the 60 cycle power line and the 144 cycle field rate of the color transmission.

A full wave rectifier 5V4 in conjunction with a condenser input filter yields a positive B plus voltage of 280 volts at 175 mils and a negative supply voltage of approximately 120 volts is obtained across a bleeder resistor between secondary center-tap and ground.

Care must be taken in the physical placement of the power transformer and other iron-core components so as to minimize the effect of any stray magnetic fields on video and vertical circuitry and the kinescope tube itself. Although the rectifier input condenser input circuit is no more elaborate from a filtering standpoint, hum reduction is further accomplished by the utilization of decoupling networks between the power supply and the appropriate circuitry.

F. - Motor Speed Control Circuits

An entirely new problem presented by the color television unit is that of motor speed control circuitry.

Color presentation is accomplished by means of a rotating filter disc (See Fig. 15), similar to that used in the camera, which is positioned before the face of the picture tube. This disc carries six filter segments (See Fig. 8), two in each of the three primary colors, red, blue and green. The disc rotates at 1440 r.p.m. and is synchronized with the 144 cycle/sec. field scanning rate of the receiver. The image formed on the screen of the picture tube is in white light and this light in passing through the colored filters, takes on successively the three primary colors. The system thus comprises two filter discs rotating in rigid synchronism, so positioned that the filters before the camera and the picture tube always have the same color at any instant. In order to synchronize the position of the receiver filter disc, the speed must be kept at 1440 r.p.m. and the phase must be automatically adjusted by means of synchronizing impulses so that the red light is produced by the receiver only when the red filter is positioned before the camera tube at the transmitter and similarly for the other two colors.

Refer to Fig. 15-Block Diagram of Motor Speed Controls

Refer to Fig. 19-Wiring Diagram of Speed Control Circuits

Speed control is accomplished by means of an automatic phase and frequency control circuit. The driving motor is a 1/20 h.p. split phase induction motor, belt coupled to the color wheel and direct coupled to a six pole alternator which when running at 1440 r.p.m. will deliver a sine-wave voltage output at a frequency of 144 cycle/sec. The frequency will of course be directly proportional to the motor speed. A balanced phase and frequency comparator consisting of a 12AU7 compares the sine-wave output from the alternator to vertical pulses at 144 cycles/sec. field rate. The control voltage generated is applied to the grid of a high gm D.C. coupled current amplifier which utilizes a 6AH6 tube. The plate current of this amplifier flows through the primary of the saturable reactor which saturates the iron core and so varies the inductance of the secondary winding in a manner which is to a first approximation inversely proportional to the primary current.

As can be noted in Fig. 19, the secondary inductance of the reactor is in series with the induction motor across the line voltage. A variation of secondary inductance will vary the 60 cycle voltage fed to the motor and thus control its speed. A color phasing potentiometer controls the D.C. bias and thus controls its speed. An anti-hunt potentiometer controls the amount of feedback from the screen of the control tube back to the input circuit.

The gain and accuracy of the control system must be high enough so that the amount of phase deviation or instability caused by normal line voltage variation or heating effects will not be large enough to permit any trace of the preceding or following color field to be visible.

As mentioned before proper color phasing is obtained only when the color of the filter at the receiver is identical to the one at the camera at any moment. The speed circuitry does not utilize any information which permits it to recognize the various color fields. It is, therefore, possible to be initially synchronized on any one of the 3 color fields when the set is turned on. The ambiguity is corrected by means of a front-control push button which momentarily shorts out the secondary of the saturable reactor thus permitting the color disc to slip free for a short period and lock itself to a new frame.

Interconnection with Black & White Receiver

The slave color converter derives composite video signal from the black-and-white receiver. The basic requirements for the interconnecting device were that it be universal in its application so that it operated with all types and makes of black-and-white receivers and that its effect on black-and-white operation due to loading be negligible.

A probe, Fig. 20, is inserted in the input video amplifier socket of the black-and-white receiver. The pin connections are connected to another tube socket at the top of the probe in which the video amplifier tube fits. A 6J6 cathode loaded stage is inside the probe and couples composite video signal from the grid of the video amplifier through 70 ohm cable to the color converter. The input loading of this cathode follower is extremely small. The polarity switch in the video amplifier circuit will accommodate either negative or positive polarity signal. Plate and filament power is fed to the cathode follower from the color converter. The probe is built in four different forms to accommodate either a 7 pin miniature, noval miniature, octal or loctal video amplifier tube in the black-and-white receiver.

The color converter chassis, cabinet, and shafts are insulated so as to avoid shock hazard when used with a black-and-white receiver of the hot-chassis type, that is, in which one side of the power line is connected to the chassis.

Overall Performance

The slave color converter unit developed by Tele-Tone provides good color picture on transmissions using the CBS field-sequential system.

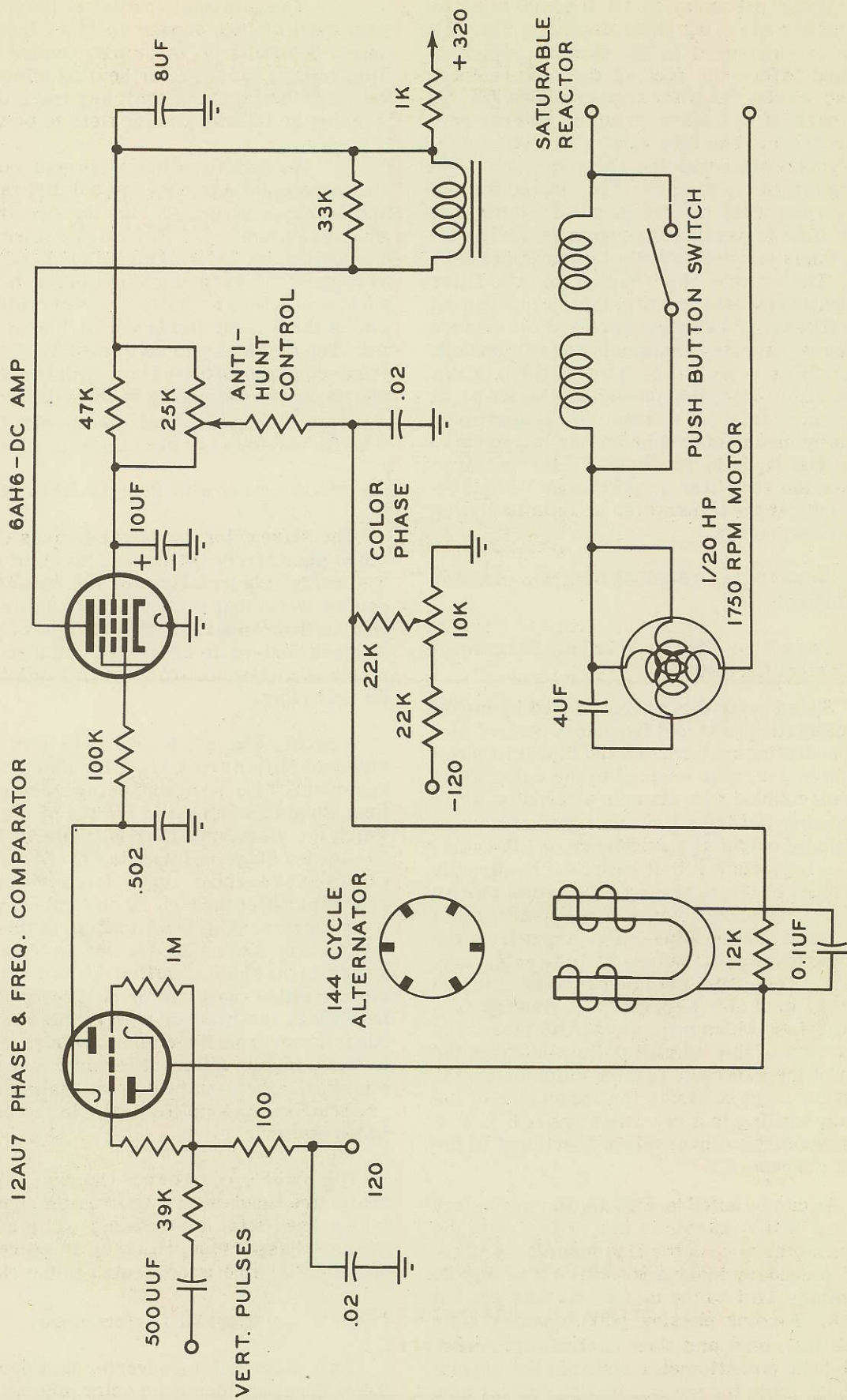

Figure 19. Motor Speed Control

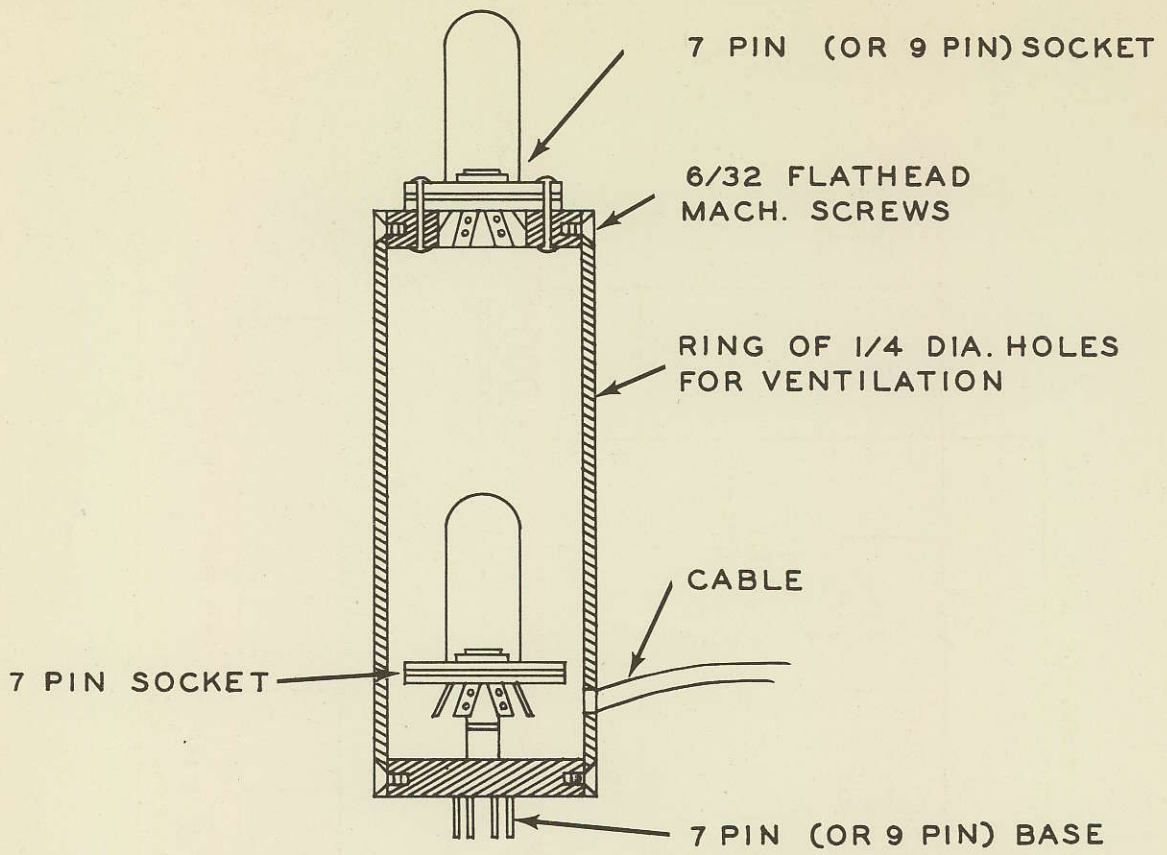

Figure 20. Probe to Connect to Black-and-White TV Receiver



COLOR

CONVERTER KITS

*Convert TV set to receive CBS Color

Kit Includes:

- MOTOR DRIVE
- COLOR WHEEL
- MOTOR SYNC COMPONENTS

We can also supply the special components required to adapt Black and White sets to CBS or dual standards.

Write today for complete data

COLOR SALES CO.

295 West Shore Dr. Massapequa, L.I.

NEW YORK

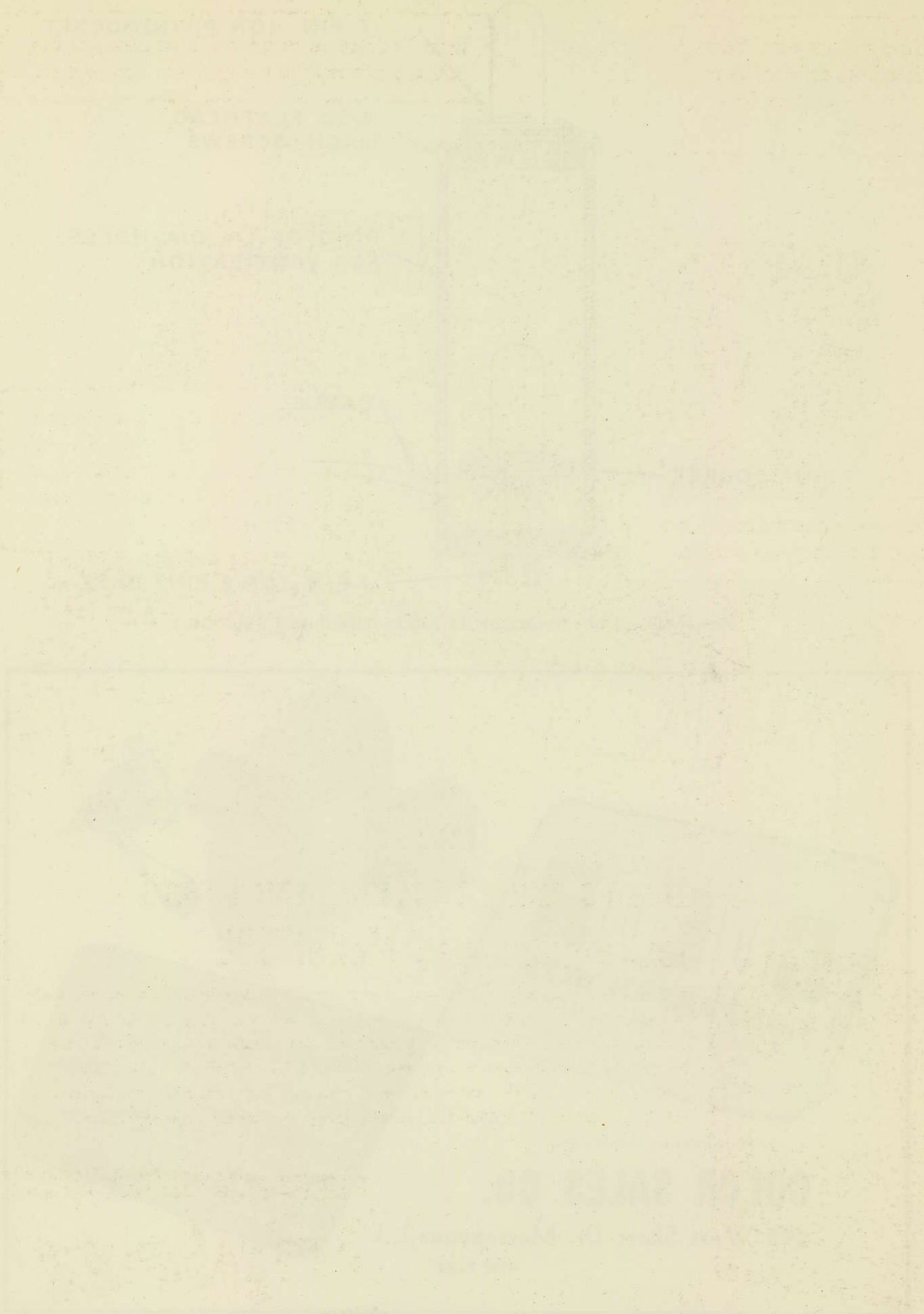

Unit switch construction houses precision resistors in insulated recesses.

Easy-to-change standard batteries. Double spiral springs give permanent connection.

Direct connections—no harness cabling—no shorts.

Molded selector switch fully enclosed. Spiral spring index control—over 150,000 cycles without breaking.

Here's why top engineers and technicians use Model 630

Features like those shown above are what make this popular V.O.M. so outstandingly dependable in the field. The enclosed switch, for instance, keeps the silvered contacts permanently clean. That's rugged construction that means stronger performance, longer life. And tests show that the spiral spring index control, after more than 150,000 cycles of switch rotation, has no disruption or appreciable wear! Investigate this history-making Volt-Ohm-Mil-Ammeter today: 33 ranges, large 5½" meter.

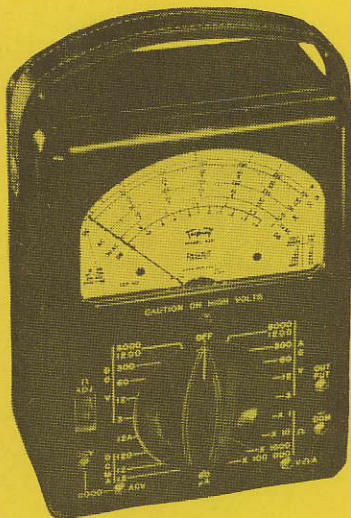

FOR THE MAN WHO TAKES PRIDE IN HIS WORK

Triplett

TRIPLETT ELECTRICAL INSTRUMENT COMPANY • BLUFFTON, OHIO, U.S.A.

It's Tung-Sol for radio and tv



Quality -that keeps pace with the growth of the electronic industry
-that meets fully the performance requirements of all
radio and tv set manufacturers
-that safeguards dealer service work

TUNG-SOL
RADIO, TV TUBES, DIAL LAMPS